

TURNLINE TAC Boring Bars

STREAMJETBAR

Extended
Version

**Highly Rigid Internal Toolholders
with Excellent Chip Evacuation**



Extensive simulation analysis has enabled Tungaloy to develop a highly-rigid Stream Jet Bar with the ideal tool geometry for excellent chip evacuation.

New MINI

Stream Jet Bar MINI **for small diameter machining applications!**

Features

● Excellent performance for small diameter machining operations

- ▼ Minimum bore diameter from $\varnothing 4.5$ mm
- ▼ Steel and carbide shank available
- ▼ Straight shank type available
- ▼ Can be used with internal coolant supply
- ▼ Well designed chip pocket for excellent chip evacuation
- ▼ Easy to adjust overhang due to marked scale on shank
- ▼ Improved rigidity for minimizing bar deflection and chatter by FEM (Finite Element Method)
- ▼ Added Z cutting edge style for back boring



Power Up

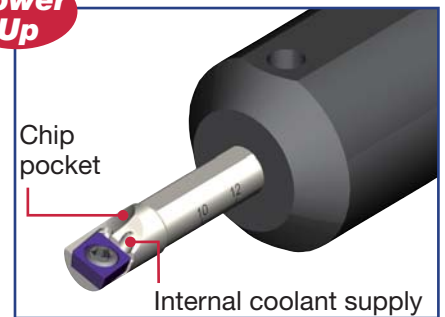

● Applicable for a wide variety of machines

- ▼ Applicable sleeve for a variety of small lathes
- ▼ Supplied with Seal cap (optional)
- ▼ Suitably designed sleeve for directed external coolant flow (see picture below)



New Seal Cap (Optional)



Attention: Please use the installation tools (e.g. a plastic hammer etc.), if difficult to ensure proper alignment

● Stable tool life and excellent chip control

- ▼ W08 type chipbreaker
- ▼ Superior cutting edge due to fine grain carbide grade
- ▼ Two grades of inserts: **SH730** (for general purpose), **TH10** (for non-ferrous)
- ▼ Expansion of corner R0.1 spec on “**EPGT04**” and “**WBG03**” insert types

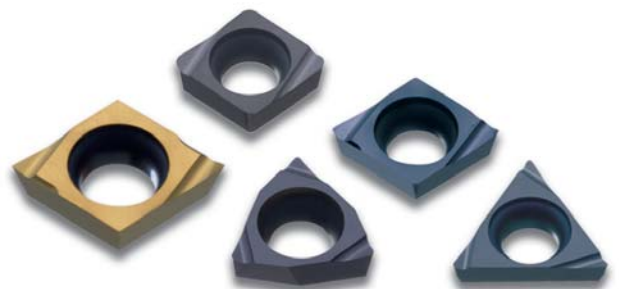

- Finite Analysis of the load transition

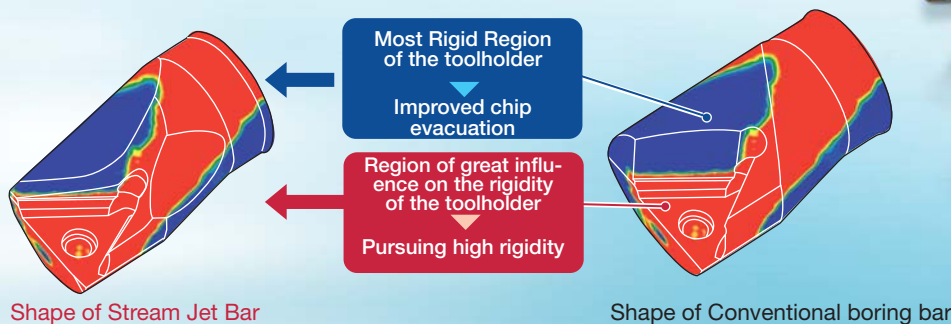

- Increased rigidity for minimizing bar deflection and chatter

- Rigidity comparison with a conventional boring bar (Illustrations)

The rigidity of the bar in the direction of the principal force is maximized because the thickest portion of the head is located as close as possible to the cutting edge.
 Note: Load 1000N ($V_c = 150$ m/min, $a_p = 1.5$ mm, $f = 0.2$ mm/rev are assumed) A16Q-STUPR13-D180

Large head design provides both high rigidity and good chip evacuation.

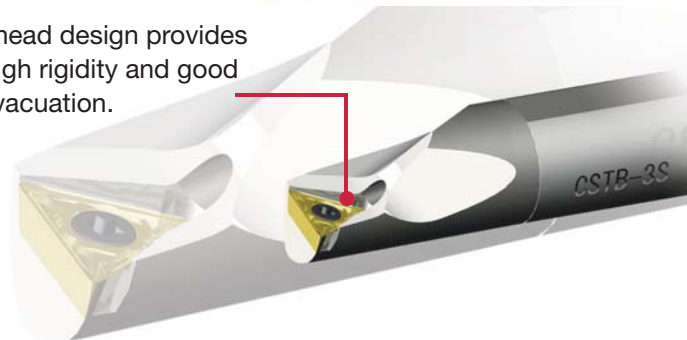

About 20% reduction in deflection compared with conventional bar

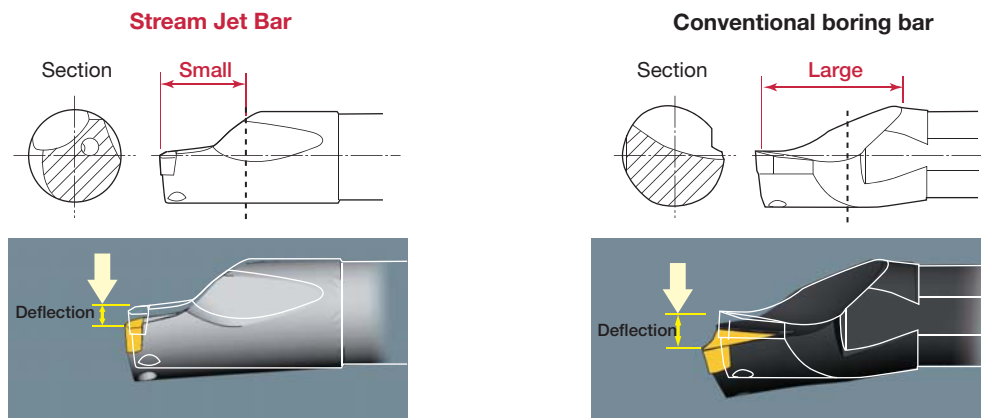

- New pocket design for excellent chip evacuation

- Cutting performance

The excellent chip evacuation minimizes tool failure caused by re-cutting chips and poor chip control. Damage to the work surface from chips is also eliminated.

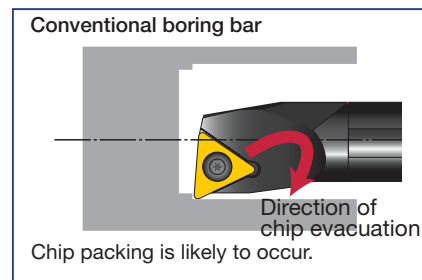
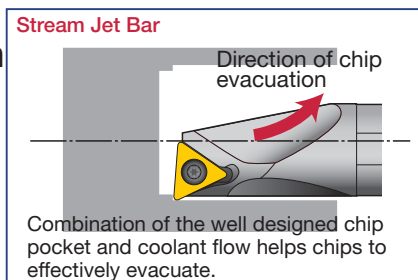

- The oil hole is positioned as close as possible to the cutting edge to ensure fluid is fed directly to the cutting point.

- Oil hole design

Distance between the cutting edge and the oil hole is minimized. (Distance is reduced by 50% compared to existing boring bars.)

- Screw for oil hole*

In the case of not using the oil hole, a special screw can be inserted to prevent chip coiling (optional).

* Negative type only

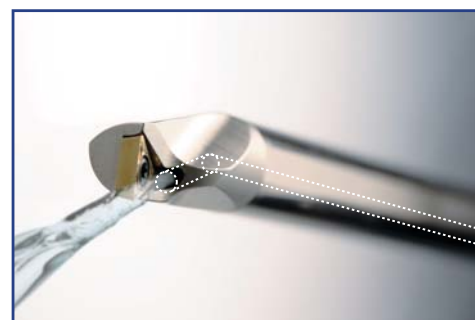

Improved tool life

By supplying the optimum level of cutting fluid, flank wear and rake face wear are suppressed, considerably improving tool life.

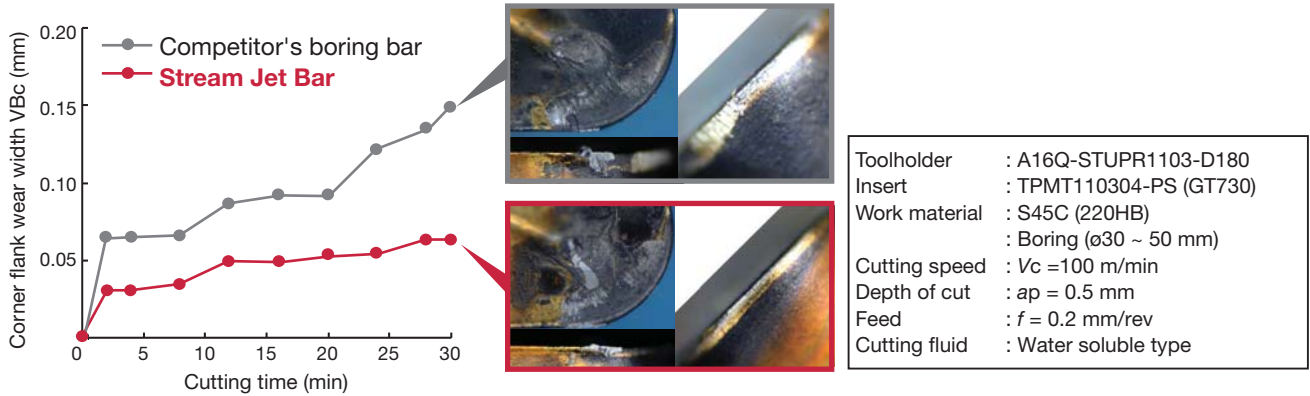

“Easy to use”

● Marking specifications

Applicable clamping screw Cat. No. (Positive type only)
If screw is missing this detail simplifies locating a replacement with Cat. No.

Scale of overhang length
Useful for easy setting of the toolholder.

Tool holder Cat. No.
The minimum bore diameter is indicated in the Cat. No. The three-digit number at the end of the text indicates the minimum bore diameter.
(Example)-D140 → 14.0 mm

Applicable insert Cat. No.
Can identify the insert size and relief angle at a glance. Simplified tool management.

Carbide shank type

Combination of the highly rigid carbide shank and the head geometry can increase the tool rigidity and improve chip evacuation.

● Guide to L/D











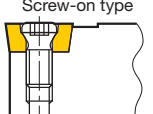

















Steel shank	Carbide shank
L/D ≤ 3	L/D ≤ 5

(Note) L : Overhang length, D : Shank diameter

● For precision boring

The increased rigidity suppresses chatter, producing excellent surface finishes. Excellent chip evacuation minimizes damage to the surface caused by chip re-cutting. This further improves surface finish.

Designation System for TAC Boring Toolholders

P Lever-lock type  S Screw-on type 	C  Rhombic 80°	Symbol Style Offset	G   J  K  L  N  P*  Q* 	S  V  U  X*  Y  Z 	with without with with with without without with	with without with with without without with	Note: *mark.-Tungaloy Standard No mark: ISO standard
	D  Rhombic 55°						
	E  Rhombic 75°						
	S  Square						
	T  Triangular						
	V  Rhombic 35°						
	Y  Y-shape Rhombic 25° (Tungaloy's symbol)						
	W  Trigon						
	A 						
	B 						
C 							
D 							
E 							
F 							

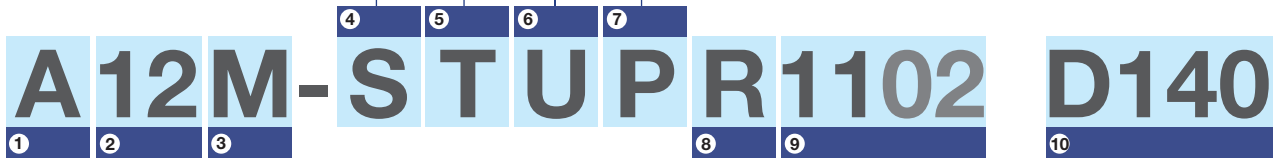





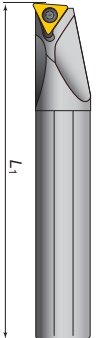

1 Bar composition	
A	Steel shank with oil hole
E	Carbide shank with steel head and oil hole

2 Bar diameter	
Bar diameter is shown in mm.	

3 Toolholder length L ₁ (mm)	
F	80
G	90
H	100
J	110
K	125
L	130
M	150
P	170
Q	180
R	200
S	250
T	300
U	350



8 Hand of tool	
R	
L	

9 Insert size ℓ + (S)	
For M, S, and C types conformed to ISO	
S	
T	
C	
R	
<p>"In ISO metric system, a two digit number indicates the edge length (ℓ) of the insert to be used in mm. If the insert thickness is different for the same edge length, add the thickness symbol (s) (two digit number)."</p> <p>In above example, TP□□1102□□ ℓ S</p>	

10 Min. bore. diameter	
Stream Jet Bars	
140	Ø14.0 mm

List of Stream Jet Bars

A wide range of styles and sizes available

Positive type

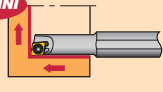
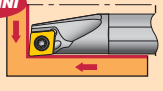
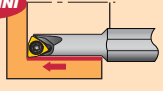
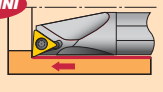
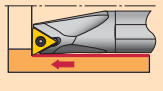
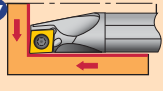
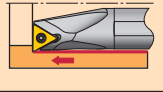
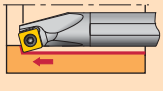
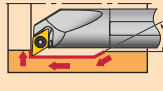
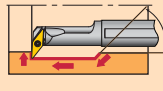
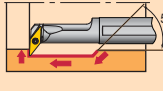
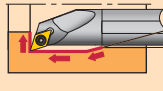
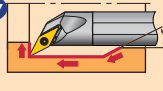
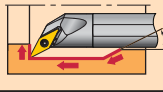
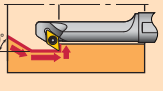
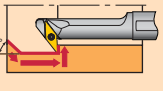
Style	Shank type	Shank diameter	Minimum bore diameter (mm)					
			0	10	20	30	40	50
New MINI  SEXPR/L P. 18 Boring and facing Insert type: EP□□	Steel	ø4 ~ ø8	ø4.5	ø7				
	Carbide	ø4 ~ ø8	ø4.5	ø7				
New MINI  SCLCR/L P. 8 Boring and facing Insert type: CC□□	Steel	ø4 ~ ø25	ø5	ø27				
	Carbide	ø4 ~ ø25	ø5	ø27				
New MINI  SWUBR/L P. 17 Boring Insert type: WB□□	Steel	ø5 ~ ø8	ø6	ø8				
	Carbide	ø5 ~ ø8	ø6	ø8				
New MINI  STUPR/L P. 14 Boring Insert type: TP□□	Steel	ø7 ~ ø32	ø8	ø34				
	Carbide	ø7 ~ ø25	ø8	ø27				
 STFPR/L P. 13 Boring Insert type: TP□□	Steel	ø8 ~ ø25	ø10	ø27				
	Carbide	ø8 ~ ø20	ø10	ø22				
New  SCLPR/L P. 9 Through boring Insert type: CP□□	Steel	ø8 ~ ø25	ø10	ø27				
	Carbide	ø8 ~ ø16	ø10	ø20				
 STFCR/L P. 12 Boring Insert type: SP□□	Steel	ø8 ~ ø25	ø10	ø27				
	Carbide	ø8 ~ ø25	ø10	ø27				
 SSKPR/L P. 11 Through boring Insert type: SP□□	Steel	ø16 ~ ø25		ø20	ø31			
 SDUCR/L P. 10 Internal profiling Insert type: DC□□	Steel	ø10 ~ ø25		ø13	ø32			
	Carbide	ø10 ~ ø20		ø13	ø27			
 SVUCR/L P. 16 Internal profiling Insert type: VC□□	Steel	ø12 ~ ø40		ø16	ø50			
	Carbide	ø12 ~ ø25		ø18	ø32			
 SVUBR/L P. 16 Internal profiling Insert type: VB□□	Steel	ø16 ~ ø25		ø20	ø32			
	Carbide	ø16 ~ ø25		ø24.5	ø34			
 SDQCR/L P. 10 Internal profiling Insert type: DC□□	Steel	ø10~ ø25	ø13	ø30				
	Carbide	ø10~ ø20	ø13	ø25				
New  SVQCR/L P. 15 Internal profiling Insert type: VC□□	Steel	ø10~ ø40	ø13.5	ø50				
	Carbide	ø10~ ø16	ø13.5	ø21.5				
 SVQBR/L P. 15 Internal profiling Insert type: VB□□	Steel	ø12 ~ ø25	ø17	ø30.5				
	Carbide	ø12 ~ ø25	ø17	ø30.5				
 SDZCR/L P. 11 Internal retracting Insert type: DC□□	Steel	ø12 ~ ø25	ø14	ø25				
	Carbide	ø12 ~ ø16	ø18	ø22				
 SVZCR/L P. 17 Internal retracting Insert type: VC□□	Steel	ø12	ø16					

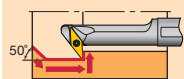
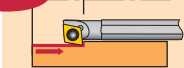
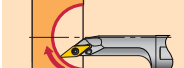
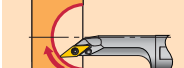
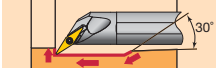
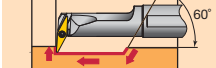
Style	Shank type	Shank diameter	Minimum bore diameter (mm)						
			0	10	20	30	40	50	
 SVZBR/L P. 16 Internal retracting Insert type: VB□□	Steel	ø16 ~ ø32			ø20	ø20 ~ ø40			
 SEZPR/L P. 17 Internal retracting Insert type: EP□□	Steel Carbide	ø4 ~ ø5	ø5.5	ø6.5					
 SVJCR/L P. 18, 19 Internal sphere cutting Insert type: VC□□	Steel	ø12 ~ ø16			ø16	ø16 ~ ø20			
 SVJBR/L P. 18, 19 Internal sphere cutting Insert type: VB□□	Steel	ø20 ~ ø25			ø25	ø25 ~ ø30			
 SYQBR/L P. 20 Internal undercut and profiling Insert type: YW□□	Steel Carbide	ø12 ~ ø16			ø17	ø17 ~ ø21.5			
 SYUBR/L P. 20 Internal profiling Insert type: YW□□	Steel Carbide	ø16			ø20	ø20 ~ ø24.5			

Negative type

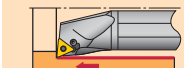
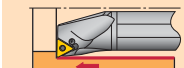
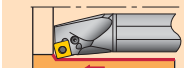
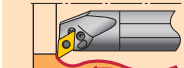
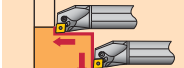
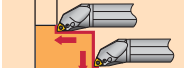
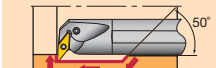
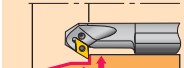
Style	Shank type	Shank diameter	Minimum bore diameter (mm)							
			0	10	20	30	40	50	60	70
 PTUNR/L P. 22 Boring Insert type: TN□□	Steel	ø16 ~ ø32			ø20	ø20 ~ ø40				
 PTFNR/L P. 22 Boring Insert type: TN□□	Steel	ø25 ~ ø50			ø32	ø32 ~ ø63				
 PSKNR/L P. 22 Through boring Insert type: SN□□	Steel	ø32 ~ ø50			ø40	ø40 ~ ø63				
 PDUNR/L P. 21 Internal profiling Insert type: DN□□	Steel	ø20 ~ ø50			ø25	ø25 ~ ø63				
 PCLNR/L P. 21 Boring and facing Insert type: CN□□	Steel	ø16 ~ ø50			ø20	ø20 ~ ø63				
 PWLNR/L P. 23 Boring and facing Insert type: WN□□	Steel	ø16 ~ ø40			ø20	ø20 ~ ø50				
 PVUNR/L P. 23 Internal profiling Insert type: VN□□	Steel	ø25 ~ ø40			ø37	ø37 ~ ø50				
 PDZNR/L P. 21 Internal retracting Insert type: DN□□	Steel	ø32 ~ ø50			ø40	ø40 ~ ø63				

Internal toolholders, positive type

SCLCR/L Boring & internal facing

S-type (Positive, screw-on)

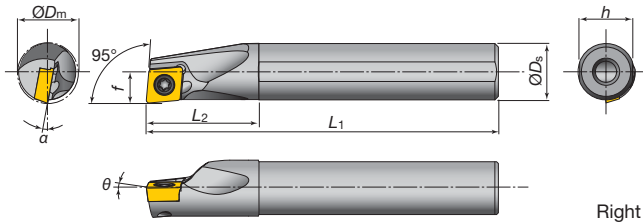
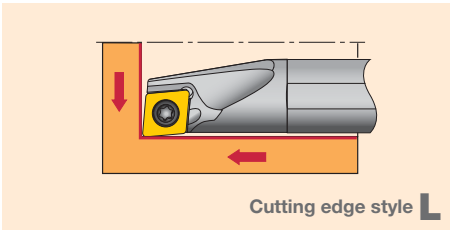

Right hand (R) shown

Steel shank

Toolholder Cat. No.	Stock		Min. bore dia. $\varnothing D_m$	Dimensions (mm)							Std. corner radius r_E	Applicable inserts	Parts		Torque (N·m)	
	R	L		$\varnothing D_s$	f	L_1	L_2	h	f_2	θ			α	Clamping screw		Wrench
New MINI A04F-SCLCR/L03-D050	●	●	5	4	2.5	80	8	3.8	-	0°	-15°	0.2	CC□□03X1	CSTA-1.6	T-6F	0.6
New MINI A05F-SCLCR/L03-D060	●	●	6	5	3	80	9	4.8	-	0°	-13°					
New MINI A06G-SCLCR/L04-D070	●	●	7	6	3.5	90	11	5.75	-	0°	-13°	0.2	CC□□04T1	CSTB-2	T-6F	0.6
New MINI A07G-SCLCR/L04-D080	●	●	8	7	4	90	12	6.75	-	0°	-11°					
A08H-SCLCR/L06-D100	●	●	10	8	5.5	100	16	7.5	-	0°	-13°	0.4	CC□□0602	CSTB-2.5S	T-8F	1.2
A10F-SCLCR/L06-D120	●	●	12	10	6	80	20	9	-	0°	-10°					
A10K-SCLCR/L06-D120	●	●	12	10	6	125	20	9	-	0°	-10°	0.4	CC□□0602	CSTB-2.5S	T-8F	1.2
A12H-SCLCR/L06-D140	●	●	14	12	7	100	24	11	-	0°	-8°					
A12M-SCLCR/L06-D140	●	●	14	12	7	150	24	11	-	0°	-8°	0.4	CC□□0602	CSTB-2.5S	T-8F	1.2
A12H-SCLCR/L06-D160	●	●	16	12	9	100	24	11	-	0°	-7°					
A12M-SCLCR/L06-D160	●	●	16	12	9	150	24	11	-	0°	-7°	0.4	CC□□0602	CSTB-2.5S	T-8F	1.2
A16K-SCLCR/L09-D180	●	●	18	16	9	125	32	15	-	0°	-9°					
A16Q-SCLCR/L09-D180	●	●	18	16	9	180	32	15	-	0°	-10°	0.8	CC□□09T3	CSTB-4S	T-15F	3.0
A16K-SCLCR/L09-D200	●	●	20	16	11	125	32	15	-	0°	-9°					
A16Q-SCLCR/L09-D200	●	●	20	16	11	180	32	15	-	0°	-9°	0.8	CC□□09T3	CSTB-4S	T-15F	3.0
A20R-SCLCR/L09-D220	●	●	22	20	11	200	32	18	-	0°	-8°					
A25S-SCLCR/L09-D270	●	●	27	25	13.5	250	45	23	-	0°	-6°	0.8	CC□□09T3	CSTB-4S	T-15F	3.0

Carbide shank

Toolholder Cat. No.	Stock		Min. bore dia. $\varnothing D_m$	Dimensions (mm)							Std. corner radius r_E	Applicable inserts	Parts		Torque (N·m)	
	R	L		$\varnothing D_s$	f	L_1	L_2	h	f_2	θ			α	Clamping screw		Wrench
New MINI E04G-SCLCR/L03-D050	●	●	5	4	2.5	90	9	3.8	-	0°	-15°	0.2	CC□□03X1	CSTA-1.6	T-6F	0.6
New MINI E05G-SCLCR/L03-D060	●	●	6	5	3	90	10	4.8	-	0°	-13°					
New MINI E06H-SCLCR/L04-D070	●	●	7	6	3.5	100	12	5.75	-	0°	-13°	0.2	CC□□04T1	CSTB-2	T-6F	0.6
New MINI E07H-SCLCR/L04-D080	●	●	8	7	4	100	14	6.75	-	0°	-11°					
E08G-SCLCR/L06-D100	●	●	10	8	5.5	90	22	7.5	-	0°	-13°	0.4	CC□□0602	CSTB-2.5S	T-8F	1.2
E08K-SCLCR/L06-D100	●	●	10	8	5.5	125	22	7.5	-	0°	-13°					
E10F-SCLCR/L06-D120	●	●	12	10	6	80	25	9	-	0°	-10°	0.4	CC□□0602	CSTB-2.5S	T-8F	1.2
E10H-SCLCR/L06-D120	●	●	12	10	6	100	25	9	-	0°	-10°					
E10M-SCLCR/L06-D120	●	●	12	10	6	150	25	9	-	0°	-10°	0.4	CC□□0602	CSTB-2.5S	T-8F	1.2
E12G-SCLCR/L06-D140	●	●	14	12	7	90	27	11	-	0°	-8°					
E12J-SCLCR/L06-D140	●	●	14	12	7	110	27	11	-	0°	-8°	0.4	CC□□0602	CSTB-2.5S	T-8F	1.2
E12Q-SCLCR/L06-D140	●	●	14	12	7	180	27	11	-	0°	-8°					
E12G-SCLCR/L06-D160	●	●	16	12	9	90	27	11	-	0°	-7°	0.4	CC□□0602	CSTB-2.5S	T-8F	1.2
E12J-SCLCR/L06-D160	●	●	16	12	9	110	27	11	-	0°	-7°					
E12Q-SCLCR/L06-D160	●	●	16	12	9	180	27	11	-	0°	-7°	0.4	CC□□0602	CSTB-2.5S	T-8F	1.2
E16H-SCLCR/L09-D180	●	●	18	16	9	100	32	15	-	0°	-10°					
E16L-SCLCR/L09-D180	●	●	18	16	9	130	32	15	-	0°	-10°	0.8	CC□□09T3	CSTB-4L060	T-15F	3.0
E16R-SCLCR/L09-D180	●	●	18	16	9	200	32	15	-	0°	-10°					
E16H-SCLCR/L09-D200	●	●	20	16	11	100	32	15	-	0°	-9°	0.8	CC□□09T3	CSTB-4L060	T-15F	3.0
E16L-SCLCR/L09-D200	●	●	20	16	11	130	32	15	-	0°	-9°					
E16R-SCLCR/L09-D200	●	●	20	16	11	200	32	15	-	0°	-9°	0.8	CC□□09T3	CSTB-4L060	T-15F	3.0
E20S-SCLCR/L09-D220	●	●	22	20	11	250	36	18	-	0°	-8°					
E25T-SCLCR/L09-D270	●	●	27	25	13.5	300	45	23	-	0°	-6°	0.8	CC□□09T3	CSTB-4S	T-15F	3.0

When using a right or left hand insert, the right hand insert (R) is used for the left hand toolholders (SCLCL □□ type), and the left hand insert (L) is used for the right hand toolholders (SCLCR □□ type).

● : Stocked items

SCLPR/L

Boring & internal facing

S-type (Positive, screw-on)

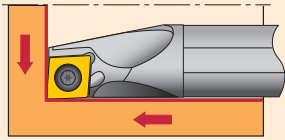

Cutting edge style **L**

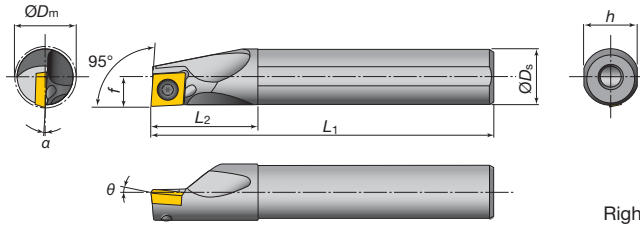

Right hand (R) shown

Steel shank

	Toolholder Cat. No.	Stock		Min. bore dia. $\varnothing D_m$	Dimensions (mm)							Std. corner radius r_ϵ	Applicable inserts	Parts		Torque (N·m)	
		R	L		$\varnothing D_s$	f	L_1	L_2	h	f_2	θ			α	Clamping screw		Wrench
New	A08H-SCLPR/L06-D100	●	●	10	8	5.5	100	16	7.5	-	+5°	-8°	0.4	CP□□0602	CSTB-2.5S	T-8F	1.2
New	A10K-SCLPR/L06-D120	●	●	12	10	6	125	20	9	-	+5°	-5°	0.4	CP□□0602	CSTB-2.5S	T-8F	1.2
	A10K-SCLPR/L08-D120	●	●	12	10	6	125	20	9	-	+5°	-5°	0.4	CP□□0802	CSTB-3L042	T-9F	1.4
New	A12M-SCLPR/L06-D140	●	●	14	12	7	150	24	11	-	+5°	-4°	0.4	CP□□0602	CSTB-2.5S	T-8F	1.2
	A12M-SCLPR/L08-D140	●	●	14	12	7	150	24	11	-	+5°	-4°	0.4	CP□□0802	CSTB-3L050	T-9F	1.4
	A12M-SCLPR/L08-D160	●	●	16	12	9	150	24	11	-	+5°	-3°	0.4				
	A16Q-SCLPR/L09-D180	●	●	18	16	9	180	32	15	-	+5°	-3.5°	0.8	CP□□0903	CSTB-4L060	T-15F	3.0
	A16Q-SCLPR/L09-D200	●	●	20	16	11	180	32	15	-	+5°	-3°	0.8				
	A20R-SCLPR/L09-D220	●	●	22	20	11	200	36	18	-	+5°	-2°	0.8				
	A25S-SCLPR/L09-D270	●	●	27	25	13.5	250	45	23	-	+5°	-1°	0.8				

Carbide shank

	Toolholder Cat. No.	Stock		Min. bore dia. $\varnothing D_m$	Dimensions (mm)							Std. corner radius r_ϵ	Applicable inserts	Parts		Torque (N·m)	
		R	L		$\varnothing D_s$	f	L_1	L_2	h	f_2	θ			α	Clamping screw		Wrench
New	E08K-SCLPR/L06-D100	●	●	10	8	5.5	125	22	7.5	-	+5°	-8°	0.4	CP□□0602	CSTB-2.5S	T-8F	1.2
New	E10M-SCLPR/L06-D120	●	●	12	10	6	150	25	9	-	+5°	-5°	0.4	CP□□0602	CSTB-2.5S	T-8F	1.2
	E10H-SCLPR/L08-D120	●		12	10	6	100	25	9	-	+5°	-5°	0.4	CP□□0802	CSTB-3L042	T-9F	1.4
	E10M-SCLPR/L08-D120	●	●	12	10	6	150	25	9	-	+5°	-5°	0.4				
New	E12Q-SCLPR/L06-D140	●	●	14	12	7	180	27	11	-	+5°	-4°	0.4	CP□□0602	CSTB-2.5S	T-8F	1.2
	E12G-SCLPR/L08-D140	●		14	12	7	90	27	11	-	+5°	-4°	0.4	CP□□0802	CSTB-3L050	T-9F	1.4
	E12J-SCLPR/L08-D140	●		14	12	7	110	27	11	-	+5°	-4°	0.4				
	E12Q-SCLPR/L08-D140	●	●	14	12	7	180	27	11	-	+5°	-4°	0.4				
	E12G-SCLPR/L08-D160	●		16	12	9	90	27	11	-	+5°	-3°	0.4				
	E12J-SCLPR/L08-D160	●		16	12	9	110	27	11	-	+5°	-3°	0.4				
	E12Q-SCLPR/L08-D160	●	●	16	12	9	180	27	11	-	+5°	-3°	0.4				
	E16H-SCLPR/L09-D180	●		18	16	9	100	32	15	-	+5°	-3.5°	0.8	CP□□0903	CSTB-4L060	T-15F	3.0
	E16L-SCLPR/L09-D180	●		18	16	9	130	32	15	-	+5°	-3.5°	0.8				
	E16R-SCLPR/L09-D180	●	●	18	16	9	200	32	15	-	+5°	-3.5°	0.8				
	E16H-SCLPR/L09-D200	●		20	16	11	100	32	15	-	+5°	-3°	0.8				
	E16L-SCLPR/L09-D200	●		20	16	11	130	32	15	-	+5°	-3°	0.8				
	E16R-SCLPR/L09-D200	●	●	20	16	11	200	32	15	-	+5°	-3°	0.8				

When using a right or left hand insert, the right hand (R) insert is used for the left hand toolholders (SCLPL □□ type), and the left hand insert (L) is used for the right hand toolholders (SCLPR □□ type).

● : Stocked items

SDQCR/L Boring & internal profiling S-type (Positive, screw-on)

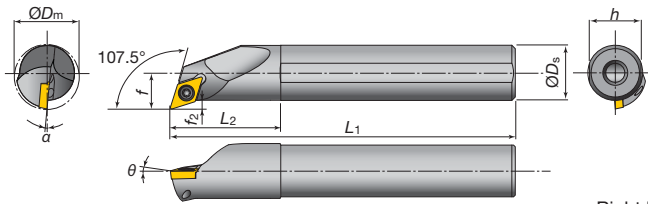
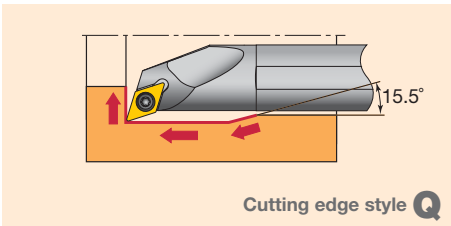

Right hand (R) shown

Steel shank

Toolholder Cat. No.	Stock		Min bore dia. $\varnothing D_m$	Dimensions (mm)							Std. corner radius r_ϵ	Applicable inserts	Parts		Torque (N·m)	
	R	L		$\varnothing D_s$	f	L_1	L_2	h	f_2	θ			a	Clamping screw		Wrench
A10K-SDQCR/L07-D130	●	●	13	10	7.6	125	20	9	2.6	0°	-8°	0.4	DC□□0702	CSTB-2.5S	T-8F	1.2
A12M-SDQCR/L07-D160	●	●	16	12	8.6	150	24	11	2.6	0°	-6°	0.4				
A16Q-SDQCR/L07-D200	●	●	20	16	10.6	180	32	15	2.6	0°	-5°	0.4				
A20R-SDQCR/L11-D250	●	●	25	20	13.7	200	36	18	3.7	0°	-7°	0.8	DC□□11T3	CSTB-4S	T-15F	3.0
A25S-SDQCR/L11-D300	●	●	30	25	16.2	250	45	23	3.7	0°	-4°	0.8				

Carbide shank

Toolholder Cat. No.	Stock		Min bore dia. $\varnothing D_m$	Dimensions (mm)							Std. corner radius r_ϵ	Applicable inserts	Parts		Torque (N·m)	
	R	L		$\varnothing D_s$	f	L_1	L_2	h	f_2	θ			a	Clamping screw		Wrench
E10H-SDQCR/L07-D130	●		13	10	7.6	100	25	9	2.5	0°	-8°	0.4	DC□□0702	CSTB-2.5S	T-8F	1.2
E10M-SDQCR/L07-D130	●	●	13	10	7.6	150	25	9	2.6	0°	-8°	0.4				
E12J-SDQCR/L07-D160	●		16	12	8.6	110	27	11	2.5	0°	-6°	0.4				
E12Q-SDQCR/L07-D160	●	●	16	12	8.6	180	27	11	2.6	0°	-6°	0.4				
E16L-SDQCR/L07-D200	●		20	16	10.6	130	32	15	2.5	0°	-5°	0.4				
E16R-SDQCR/L07-D200	●	●	20	16	10.6	200	32	15	2.6	0°	-5°	0.4				
E20S-SDQCR/L11-D250	●	●	25	20	13.7	250	36	18	3.7	0°	-7°	0.8	DC□□11T3	CSTB-4S	T-15F	3.0

When using a right or left hand insert, the right hand insert (R) is used for the left hand toolholders (SDQCL □□ type), and the left hand insert (L) is used for the right hand toolholders (SDQCR □□ type).

SDUCR/L Boring & internal profiling S-type (Positive, screw-on)

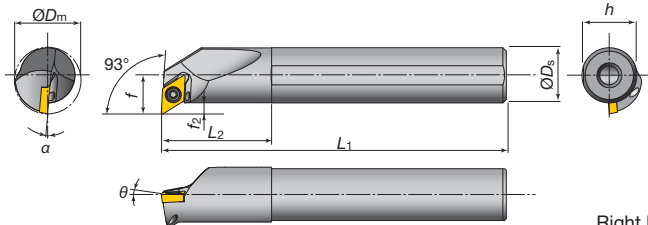
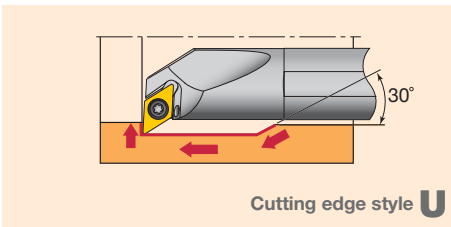

Right hand (R) shown

Steel shank

Toolholder Cat. No.	Stock		Min bore dia. $\varnothing D_m$	Dimensions (mm)							Std. corner radius r_ϵ	Applicable inserts	Parts		Torque (N·m)	
	R	L		$\varnothing D_s$	f	L_1	L_2	h	f_2	θ			a	Clamping screw		Wrench
A10K-SDUCR/L07-D130	●	●	13	10	7	125	20	9	2.0	0°	-10°	0.4	DC□□0702	CSTB-2.5S	T-8F	1.2
A12M-SDUCR/L07-D160	●	●	16	12	9.3	150	24	11	3.3	0°	-6°	0.4				
A16Q-SDUCR/L07-D200	●	●	20	16	11.3	180	32	15	3.3	0°	-5°	0.4		DC□□11T3	CSTB-4S	
A20R-SDUCR/L11-D270	●	●	27	20	16.1	200	36	18	6.1	0°	-5°	0.8				
A25S-SDUCR/L11-D320	●	●	32	25	18.6	250	45	23	6.1	0°	-4°	0.8				

Carbide shank

Toolholder Cat. No.	Stock		Min bore dia. $\varnothing D_m$	Dimensions (mm)							Std. corner radius r_ϵ	Applicable inserts	Parts		Torque (N·m)	
	R	L		$\varnothing D_s$	f	L_1	L_2	h	f_2	θ			a	Clamping screw		Wrench
E10H-SDUCR/L07-D130	●		13	10	7	100	25	9	1.9	5°	-3.5°	0.4	DC□□0702	CSTB-2.5S	T-8F	1.2
E10M-SDUCR/L07-D130	●	●	13	10	7	150	25	9	2.0	0°	-10°	0.4				
E12J-SDUCR/L07-D160	●		16	12	9.3	110	27	11	3.2	0°	-6°	0.4				
E12Q-SDUCR/L07-D160	●	●	16	12	9.3	180	27	11	3.3	0°	-6°	0.4				
E16L-SDUCR/L07-D200	●		20	16	11.3	130	32	15	3.2	0°	-5°	0.4				
E16R-SDUCR/L07-D200	●	●	20	16	11.3	200	32	15	3.3	0°	-5°	0.4				
E20S-SDUCR/L11-D270	●		27	20	16.1	250	36	18	6.1	0°	-5°	0.8	DC□□11T3	CSTB-4S	T-15F	3.0

When using a right or left hand insert, the right hand insert (R) is used for the left hand toolholders (SDUCL □□ type), and the left hand insert (L) is used for the right hand toolholders (SDUCR □□ type).

● : Stocked items

SDZCR/L

Internal retracting

S-type (Positive, screw-on)

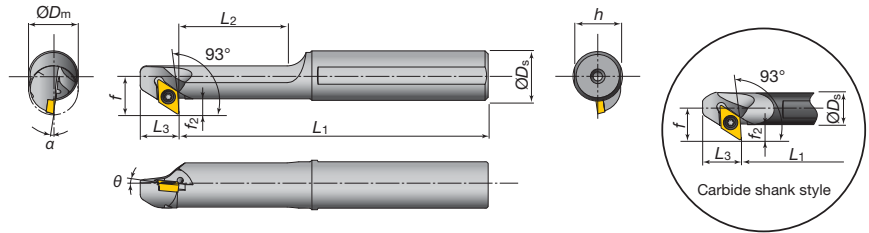
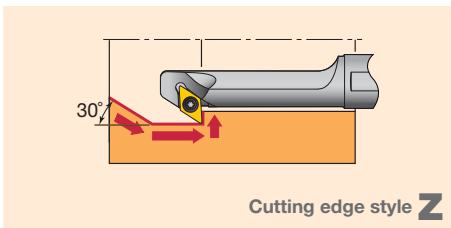

Steel shank

Toolholder Cat. No.	Stock		Min bore dia. $\varnothing D_m$	Dimensions (mm)									Std. corner radius r_ϵ	Applicable inserts	Parts		Torque (N·m)
	R	L		$\varnothing D_s$	f	L_1	L_2	L_3	h	f_2	θ	α			Clamping screw	Wrench	
A12M-SDZCR/L07-D140	●	●	14	12	10.5	150	30	12.5	11	4.5	0°	-9°	0.4	DC□□0702	CSTB-2.5	T-8F	1.2
A16Q-SDZCR/L07-D160	●	●	16	16	12.5	180	35	12.5	15	4.5	0°	-8°	0.4				
A20R-SDZCR/L11-D200	●	●	20	20	15.5	200	40	15	18	5.5	0°	-8°	0.8	DC□□11T3	CSTB-4S	T-15F	3.0
A25S-SDZCR/L11-D250	●	●	25	25	18	250	50	15	23	5.5	0°	-6°	0.8				

Carbide shank

Toolholder Cat. No.	Stock		Min bore dia. $\varnothing D_m$	Dimensions (mm)									Std. corner radius r_ϵ	Applicable inserts	Parts		Torque (N·m)
	R	L		$\varnothing D_s$	f	L_1	L_2	L_3	h	f_2	θ	α			Clamping screw	Wrench	
E12Q-SDZCR/L07-D180	●	●	18	12	10.5	180	-	12.5	11	4.5	0°	-8°	0.4	DC□□0702	CSTB-2.5	T-8F	1.2
E16R-SDZCR/L07-D220	●	●	22	16	12.5	200	-	12.5	15	4.5	0°	-6°	0.4				

When using a right or left hand insert, the right hand insert (R) is used for the right hand toolholders (SDZCR □□ type), and the left hand insert (L) is used for the left hand toolholders (SDZCL □□ type).

SSKPR/L

Through boring

S-type (Positive, screw-on)

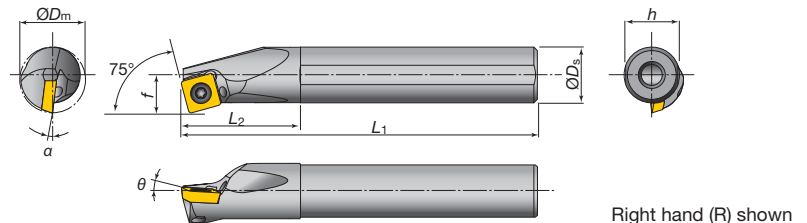
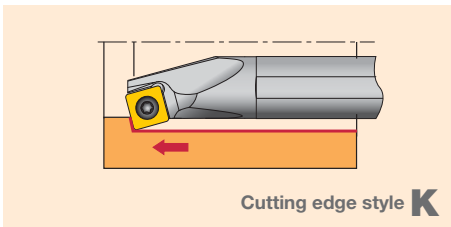

Steel shank

Toolholder Cat. No.	Stock		Min bore dia. $\varnothing D_m$	Dimensions (mm)									Std. corner radius r_ϵ	Applicable inserts	Parts		Torque (N·m)
	R	L		$\varnothing D_s$	f	L_1	L_2	h	f_2	θ	α	Clamping screw			Wrench		
A16Q-SSKPR/L09-D200	●		20	16	11	180	32	15	-	+5°	-6°	0.8	SP□□0903	CSTB-4L060	T-15F	3.0	
A20R-SSKPR/L09-D240	●		24	20	13	200	36	18	-	+5°	-2°	0.8					
A25S-SSKPR/L12-D310	●		31	25	17	250	45	23	-	+5°	-2°	0.8					SP□□1204

When using a right or left hand insert, the right hand insert (R) is used for the left hand toolholders (SSKPL □□ type), and the left hand insert (L) is used for the right hand toolholders (SSKPR □□ type).

● : Stocked items

STFCR/L Boring S-type (Positive, screw-on)

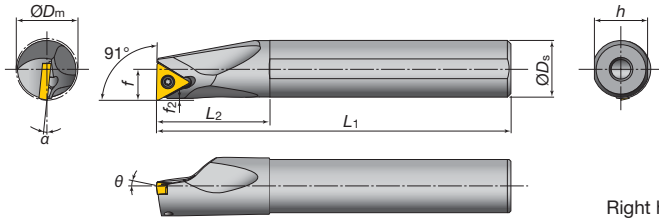
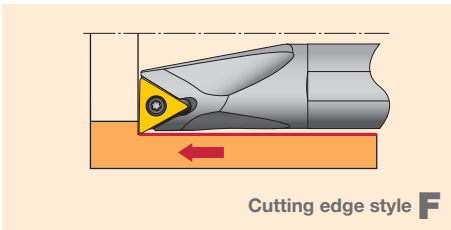

Right hand (R) shown

Steel shank

Toolholder Cat. No.	Stock		Min. bore dia. $\varnothing D_m$	Dimensions (mm)								Std. corner radius r_c	Applicable inserts	Parts		Torque (N·m)
	R	L		$\varnothing D_s$	f	L_1	L_2	h	f_2	θ	α			Clamping screw	Wrench	
A08H-STFCR/L09-D100			10	8	5.5	100	16	7.5	0.6	0°	-12°	0.4	TC□□0902	CSTB-2.2S	T-7F	0.9
A10K-STFCR/L09-D120			12	10	6.5	125	20	9	0.6	0°	-10°	0.4				
A10K-STFCR/L1102-D120			12	10	6.5	125	20	9	0.6	0°	-10°	0.4	TC□□1102	CSTB-2.5	T-8F	1.2
New A10K-STFCR/L1103-D120	●	●	12	10	6.5	125	20	9	0.6	0°	-13°	0.4	TC□□1103	CSTB-2.5	T-8F	1.2
A12M-STFCR/L09-D140			14	12	7	150	24	11	0.5	0°	-8°	0.4	TC□□0902	CSTB-2.2	T-7F	0.9
A12M-STFCR/L1102-D140			14	12	7	150	24	11	0.5	0°	-8°	0.4	TC□□1102	CSTB-2.5	T-8F	1.2
New A12M-STFCR/L1103-D140	●	●	14	12	7	150	24	11	0.5	0°	-10°	0.4	TC□□1103	CSTB-2.5	T-8F	1.2
A16Q-STFCR/L09-D180			18	16	9	180	32	15	0.6	0°	-6°	0.4	TC□□0902	CSTB-2.2	T-7F	0.9
A16Q-STFCR/L1102-D180			18	16	9	180	32	15	0.6	0°	-6°	0.4	TC□□1102	CSTB-2.5	T-8F	1.2
New A16Q-STFCR/L1103-D180	●	●	18	16	9	180	32	15	0.5	0°	-7°	0.4	TC□□1103	CSTB-2.5	T-8F	1.2
A20R-STFCR/L1102-D220			22	20	11	200	36	18	0.5	0°	-4°	0.4	TC□□1102	CSTB-2.5	T-8F	1.2
A20R-STFCR/L16-D220			22	20	11	200	36	18	0.4	0°	-7°	0.8	TC□□16T3	CSTB-4M	T-15F	3.0
A25S-STFCR/L16-D270			27	25	13.5	250	45	23	0.4	0°	-5°	0.8				

Carbide shank

Toolholder Cat. No.	Stock		Min. bore dia. $\varnothing D_m$	Dimensions (mm)								Std. corner radius r_c	Applicable inserts	Parts		Torque (N·m)
	R	L		$\varnothing D_s$	f	L_1	L_2	h	f_2	θ	α			Clamping screw	Wrench	
E08K-STFCR/L09-D100			10	8	5.5	125	22	7.5	0.6	0°	-12°	0.4	TC□□0902	CSTB-2.2S	T-7F	0.9
E10M-STFCR/L09-D120			12	10	6.5	150	25	9	0.6	0°	-10°	0.4				
E10M-STFCR/L1102-D120			12	10	6.5	150	25	9	0.6	0°	-10°	0.4	TC□□1102	CSTB-2.5	T-8F	1.2
New E10M-STFCR/L1103-D120	●	●	12	10	6.5	150	25	9	0.7	0°	-13°	0.4	TC□□1103	CSTB-2.5	T-8F	1.2
E12Q-STFCR/L09-D140			14	12	7	180	27	11	0.6	0°	-8°	0.4	TC□□0902	CSTB-2.2	T-7F	0.9
E12Q-STFCR/L1102-D140			14	12	7	180	27	11	0.6	0°	-8°	0.4	TC□□1102	CSTB-2.5	T-8F	1.2
New E12Q-STFCR/L1103-D140	●	●	14	12	7	180	27	11	0.5	0°	-10°	0.4	TC□□1103	CSTB-2.5	T-8F	1.2
E16R-STFCR/L09-D180			18	16	9	200	32	15	0.6	0°	-6°	0.4	TC□□0902	CSTB-2.2	T-7F	0.9
E16R-STFCR/L1102-D180			18	16	9	200	32	15	0.6	0°	-6°	0.4	TC□□1102	CSTB-2.5	T-8F	1.2
New E16R-STFCR/L1103-D180	●	●	18	16	9	200	32	15	0.5	0°	-7°	0.4	TC□□1103	CSTB-2.5	T-8F	1.2
E20S-STFCR/L1102-D220			22	20	11	250	36	18	0.6	0°	-4°	0.4	TC□□1102	CSTB-2.5	T-8F	1.2
E20S-STFCR/L16-D220			22	20	11	250	36	18	0.6	0°	-7°	0.8	TC□□16T3	CSTB-4M	T-15F	3.0
E25T-STFCR/L16-D270			27	25	13.5	300	45	23	0.5	0°	-5°	0.8				

When using a right or left hand insert, the right hand insert (R) is used for the left hand toolholders (STFCL □□ type), and the left hand insert (L) is used for the right hand toolholders (STFCR □□ type).

● : Stocked items

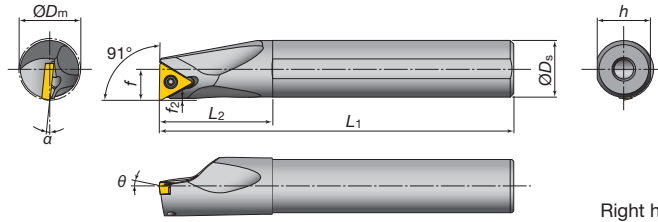
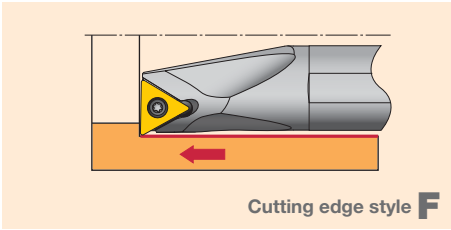

Right hand (R) shown

Steel shank

Toolholder Cat. No.	Stock		Min. bore dia. $\varnothing D_m$	Dimensions (mm)								Std. corner radius r_c	Applicable inserts	Parts		Torque (N·m)
	R	L		$\varnothing D_s$	f	L_1	L_2	h	f_2	θ	α			Clamping screw	Wrench	
A08H-STFPR/L09-D100	●	●	10	8	5.5	100	16	7.5	0.7	+5°	-8°	0.4	TP□□0902	CSTB-2.2S	T-7F	0.9
A10K-STFPR/L1102-D120	●	●	12	10	6.5	125	20	9	0.7	+5°	-6°	0.4	TP□□1102	CSTB-2.5B	T-8F	1.2
A10K-STFPR/L1103-D120			12	10	6.5	125	20	9	0.7	+5°	-7°	0.4	TP□□1103*	CSTB-3L050	T-9F	1.4
A12M-STFPR/L1102-D140	●	●	14	12	7	150	24	11	0.6	+5°	-4°	0.4	TP□□1102	CSTB-2.5	T-8F	1.2
A12M-STFPR/L1103-D140			14	12	7	150	24	11	0.6	+5°	-4°	0.4	TP□□1103*	CSTB-3S	T-9F	1.4
A16Q-STFPR/L1103-D180			18	16	9	180	32	15	0.7	+5°	-2°	0.4		CSTB-3S	T-9F	1.4
A16Q-STFPR/L13-D180	●	●	18	16	9	180	32	15	0.7	+5°	-2°	0.4	TP□□1303	CSTB-3S	T-9F	1.4
A20R-STFPR/L13-D220	●		22	20	11	200	36	18	0.8	+5°	-2°	0.4		CSTB-3	T-9F	1.4
A25S-STFPR/L16-D270	●		27	25	13.5	250	45	23	0.6	+5°	-1°	0.4	TP□□16T3	CSTB-4M	T-15F	3.0

Carbide shank

Toolholder Cat. No.	Stock		Min. bore dia. $\varnothing D_m$	Dimensions (mm)								Std. corner radius r_c	Applicable inserts	Parts		Torque (N·m)
	R	L		$\varnothing D_s$	f	L_1	L_2	h	f_2	θ	α			Clamping screw	Wrench	
E08K-STFPR/L09-D100	●	●	10	8	5.5	125	22	7.5	0.7	+5°	-8°	0.4	TP□□0902	CSTB-2.2S	T-7F	0.9
E10M-STFPR/L1102-D120	●	●	12	10	6.5	150	25	9	0.7	+5°	-6°	0.4	TP□□1102	CSTB-2.5B	T-8F	1.2
E10M-STFPR/L1103-D120			12	10	6.5	150	25	9	0.7	+5°	-7°	0.4	TP□□1103*	CSTB-3L050	T-9F	1.4
E12Q-STFPR/L1102-D140	●	●	14	12	7	180	27	11	0.6	+5°	-4°	0.4	TP□□1102	CSTB-2.5	T-8F	1.2
E12Q-STFPR/L1103-D140			14	12	7	180	27	11	0.6	+5°	-4°	0.4	TP□□1103*	CSTB-3S	T-9F	1.4
E16R-STFPR/L1103-D180			18	16	9	200	32	15	0.7	+5°	-2°	0.4		CSTB-3S	T-9F	1.4
E16R-STFPR/L13-D180	●		18	16	9	200	32	15	0.7	+5°	-2°	0.4	TP□□1303	CSTB-3S	T-9F	1.4
E20S-STFPR/L13-D220	●		22	20	11	250	36	18	0.8	+5°	-2°	0.4		CSTB-3	T-9F	1.4

When using a right or left hand insert, the right hand insert (R) is used for the left hand toolholders (STFPL □□ type), and the left hand insert (L) is used for the right hand toolholders (STFPR □□ type).

* TPGH1103 □□ is not applicable.

● : Stocked items

STUPR/L Boring S-type (Positive, screw-on)

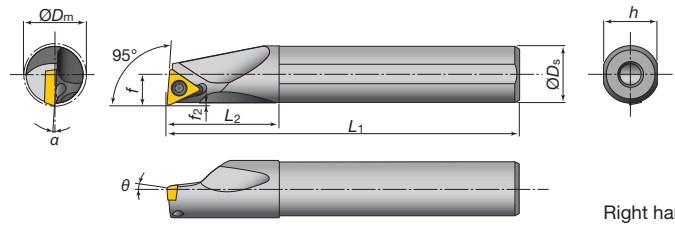
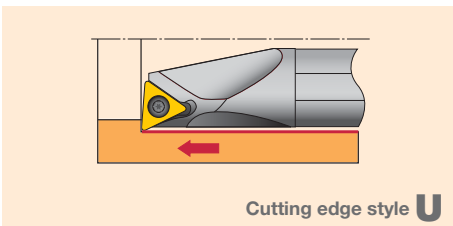

Right hand (R) shown

Steel shank

Toolholder Cat. No.	Stock		Min. bore dia. ϕD_m	Dimensions (mm)								Std. corner radius r_E	Applicable inserts	Parts		Torque (N·m)
	R	L		ϕD_s	f	L_1	L_2	h	f_2	θ	α			Clamping screw	Wrench	
New MINI A07G-STUPR/L07-D080	●	●	8	7	4	90	12	6.75	0.4	+5°	-10°	0.4	TP□□0701	CSTB-2.2L038	T-7F	0.9
A08H-STUPR/L07-D080	●	●	8	8	4	100	19.5	7.5	0.5	+5°	-10°	0.4	TP□□0701	CSTB-2.2L038	T-7F	0.9
A08H-STUPR/L09-D100	●	●	10	8	5.5	100	16	7.5	0.6	+5°	-8°	0.4	TP□□0902	CSTB-2.2L038	T-7F	0.9
A10F-STUPR/L1102-D120	●		12	10	6.5	80	20	9	1.4	+5°	-6°	0.4	TP□□1102	CSTB-2.5S	T-8F	1.2
A10K-STUPR/L1102-D120	●	●	12	10	6.5	125	20	9	0.7	+5°	-6°	0.4	TP□□1103*	CSTB-3L050	T-9F	1.4
A10K-STUPR/L1103-D120	●	●	12	10	6.5	125	20	9	0.6	+5°	-10°	0.4	TP□□1103*	CSTB-3L050	T-9F	1.4
A12H-STUPR/L1102-D140	●		14	12	7	100	24	11	0.9	+5°	-4°	0.4	TP□□1102	CSTB-2.5B	T-8F	1.2
A12M-STUPR/L1102-D140	●	●	14	12	7	150	24	11	0.7	+5°	-4°	0.4	TP□□1102	CSTB-2.5B	T-8F	1.2
A12M-STUPR/L1103-D140	●	●	14	12	7	150	24	11	0.6	+5°	-6°	0.4	TP□□1103*	CSTB-3L050	T-9F	1.4
A12H-STUPR/L1102-D160	●		16	12	9	100	24	11	0.6	+5°	-3°	0.4	TP□□1102	CSTB-2.5B	T-8F	1.2
A12M-STUPR/L1102-D160	●	●	16	12	9	150	24	11	0.6	+5°	-3°	0.4	TP□□1102	CSTB-2.5B	T-8F	1.2
A16K-STUPR/L13-D180	●		18	16	9	125	32	15	0.9	+5°	-3°	0.4	TP□□1303	CSTB-3S	T-9F	1.4
A16Q-STUPR/L1103-D180	●	●	18	16	9	180	32	15	0.8	+5°	-4°	0.4	TP□□1103*	CSTB-3S	T-9F	1.4
A16Q-STUPR/L13-D180	●	●	18	16	9	180	32	15	0.6	+5°	-3°	0.4	TP□□1303	CSTB-3S	T-9F	1.4
A16K-STUPR/L13-D200	●		20	16	11	125	32	15	0.6	+5°	-3°	0.4	TP□□1303	CSTB-3S	T-9F	1.4
A16Q-STUPR/L13-D200	●	●	20	16	11	180	32	15	0.6	+5°	-3°	0.4	TP□□1303	CSTB-3S	T-9F	1.4
A20R-STUPR/L1103-D220	●	●	22	20	11	200	36	18	0.7	+5°	-2°	0.4	TP□□1103*	CSTB-3S	T-9F	1.4
A20R-STUPR/L13-D220	●	●	22	20	11	200	36	18	0.7	+5°	-2°	0.4	TP□□1303	CSTB-3	T-9F	1.4
A25S-STUPR/L16-D270	●	●	27	25	13.5	250	45	23	0.5	+5°	-1°	0.8	TP□□16T3	CSTB-4M	T-15F	3.0
A32T-STUPR/L16-D340	●	●	34	32	17	300	50	30	0.7	+5°	0°	0.8	TP□□16T3	CSTB-4M	T-15F	3.0

Carbide shank

Toolholder Cat. No.	Stock		Min. bore dia. ϕD_m	Dimensions (mm)								Std. corner radius r_E	Applicable inserts	Parts		Torque (N·m)
	R	L		ϕD_s	f	L_1	L_2	h	f_2	θ	α			Clamping screw	Wrench	
New MINI E07H-STUPR/L07-D080	●	●	8	7	4	100	14	6.75	0.3	+5°	-10°	0.4	TP□□0701	CSTB-2.2L038	T-7F	0.9
E08G-STUPR/L07-D080	●		8	8	4	90	44.5	7.5	0.5	+5°	-10°	0.4	TP□□0701	CSTB-2.2L038	T-7F	0.9
E08K-STUPR/L07-D080	●	●	8	8	4	125	44.5	7.5	0.5	+5°	-10°	0.4	TP□□0701	CSTB-2.2L038	T-7F	0.9
E08G-STUPR/L09-D100	●		10	8	5.5	90	22	7	0.6	+5°	-8°	0.4	TP□□0902	CSTB-2.2L038	T-7F	0.9
E08K-STUPR/L09-D100	●	●	10	8	5.5	125	22	7	0.6	+5°	-8°	0.4	TP□□0902	CSTB-2.2L038	T-7F	0.9
E10F-STUPR/L1102-D120	●		12	10	6.5	80	25	9	0.5	+5°	-6°	0.4	TP□□1102	CSTB-2.5S	T-8F	1.2
E10H-STUPR/L1102-D120	●		12	10	6.5	100	25	9	0.6	+5°	-6°	0.4	TP□□1102	CSTB-2.5S	T-8F	1.2
E10M-STUPR/L1102-D120	●	●	12	10	6.5	150	25	9	0.6	+5°	-6°	0.4	TP□□1102	CSTB-2.5S	T-8F	1.2
E10M-STUPR/L1103-D120	●	●	12	10	6.5	150	25	9	0.7	+5°	-10°	0.4	TP□□1103*	CSTB-3L050	T-9F	1.4
E12G-STUPR/L1102-D140	●		14	12	7	90	27	11	0.9	+5°	-4°	0.4	TP□□1102	CSTB-2.5B	T-8F	1.2
E12J-STUPR/L1102-D140	●		14	12	7	110	27	11	0.6	+5°	-4°	0.4	TP□□1102	CSTB-2.5B	T-8F	1.2
E12Q-STUPR/L1102-D140	●	●	14	12	7	180	27	11	0.6	+5°	-4°	0.4	TP□□1102	CSTB-2.5B	T-8F	1.2
E12Q-STUPR/L1103-D140	●	●	14	12	7	180	27	11	0.7	+5°	-6°	0.4	TP□□1103*	CSTB-3L050	T-9F	1.4
E12G-STUPR/L1102-D160	●		16	12	9	90	27	11	0.6	+5°	-3°	0.4	TP□□1102	CSTB-2.5B	T-8F	1.2
E12J-STUPR/L1102-D160	●		16	12	9	110	27	11	0.6	+5°	-3°	0.4	TP□□1102	CSTB-2.5B	T-8F	1.2
E12Q-STUPR/L1102-D160	●	●	16	12	9	180	27	11	0.6	+5°	-3°	0.4	TP□□1102	CSTB-2.5B	T-8F	1.2
E16H-STUPR/L13-D180	●		18	16	9	100	32	15	0.9	+5°	-3°	0.4	TP□□1303	CSTB-3S	T-9F	1.4
E16R-STUPR/L1103-D180	●	●	18	16	9	200	32	15	0.8	+5°	-4°	0.4	TP□□1103*	CSTB-3S	T-9F	1.4
E16L-STUPR/L13-D180	●		18	16	9	130	32	15	0.6	+5°	-3°	0.4	TP□□1303	CSTB-3S	T-9F	1.4
E16R-STUPR/L13-D180	●	●	18	16	9	200	32	15	0.6	+5°	-3°	0.4	TP□□1303	CSTB-3S	T-9F	1.4
E16H-STUPR/L13-D200	●		20	16	11	100	32	15	0.6	+5°	-3°	0.4	TP□□1303	CSTB-3S	T-9F	1.4
E16L-STUPR/L13-D200	●		20	16	11	130	32	15	0.6	+5°	-3°	0.4	TP□□1303	CSTB-3S	T-9F	1.4
E16R-STUPR/L13-D200	●	●	20	16	11	200	32	15	0.6	+5°	-3°	0.4	TP□□1303	CSTB-3S	T-9F	1.4
E20S-STUPR/L1103-D220	●		22	20	11	250	36	18	0.7	+5°	-2°	0.4	TP□□1103*	CSTB-3S	T-9F	1.4
E20S-STUPR/L13-D220	●		22	20	11	250	36	18	0.6	+5°	-2°	0.4	TP□□1303	CSTB-3	T-9F	1.4
E25T-STUPR/L16-D270	●		27	25	13.5	300	45	23	0.5	+5°	-1°	0.8	TP□□16T3	CSTB-4M	T-15F	3.0

When using a right or left hand insert, the right hand insert (R) is used for the left hand toolholders (STUPL □□ type), and the left hand insert (L) is used for the right hand toolholders (STUPR □□ type). ● : Stocked items
 * TPGH1103 □□ is not applicable.

SVQBR/L

Boring & internal profiling

S-type (Positive, screw-on)

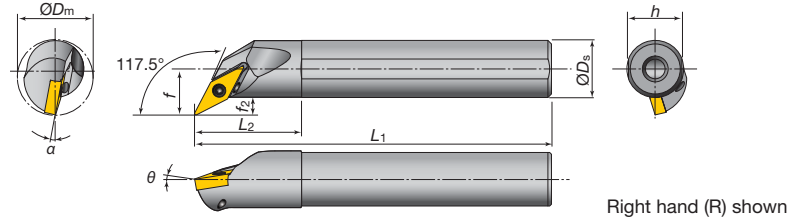
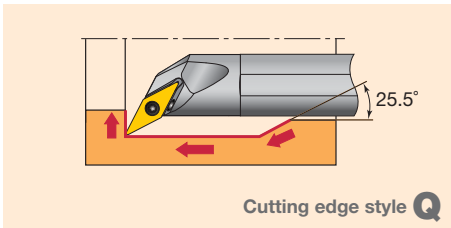

Steel shank

Toolholder Cat. No.	Stock		Min. bore dia. $\varnothing D_m$	Dimensions (mm)							Std. corner radius r_E	Applicable inserts	Parts		Torque (N·m)	
	R	L		$\varnothing D_s$	f	L_1	L_2	h	f_2	θ			α	Clamping screw		Wrench
A12M-SVQBR/L11-D170	●	●	17	12	10.5	150	24	11	4.5	-5°	-10°	0.4	VB□□1103	CSTB-2.5	T-8F	1.2
A16Q-SVQBR/L11-D215	●	●	21.5	16	13	180	30	15	5	-5°	-8°	0.4				
A20R-SVQBR/L11-D255	●	●	25.5	20	15	200	36	18	5	-5°	-6°	0.4				
A25S-SVQBR/L16-D305	●	●	30.5	25	17.5	250	45	23	5	-5°	-8°	0.8	VB□□1604	CSTB-3.5	T-15F	3.0

Carbide shank

Toolholder Cat. No.	Stock		Min. bore dia. $\varnothing D_m$	Dimensions (mm)							Std. corner radius r_E	Applicable inserts	Parts		Torque (N·m)	
	R	L		$\varnothing D_s$	f	L_1	L_2	h	f_2	θ			α	Clamping screw		Wrench
E12Q-SVQBR/L11-D170	●	●	17	12	10.5	180	27	11	4.5	-5°	-10°	0.4	VB□□1103	CSTB-2.5	T-8F	1.2
E16R-SVQBR/L11-D215	●	●	21.5	16	13	200	32	15	5	-5°	-8°	0.4				
E20S-SVQBR/L11-D255	●	●	25.5	20	15	250	36	18	5	-5°	-6°	0.4				
E25T-SVQBR/L16-D305	●	●	30.5	25	17.5	300	45	23	5	-5°	-8°	0.8	VB□□1604	CSTB-3.5	T-15F	3.0

When using a right or left hand insert, the right hand insert (R) is used for the left hand toolholders (SVQBL □□ type), and the left hand insert (L) is used for the right hand toolholders (SVQBR □□ type).

SVQCR/L

Boring & internal profiling

S-type (Positive, screw-on)

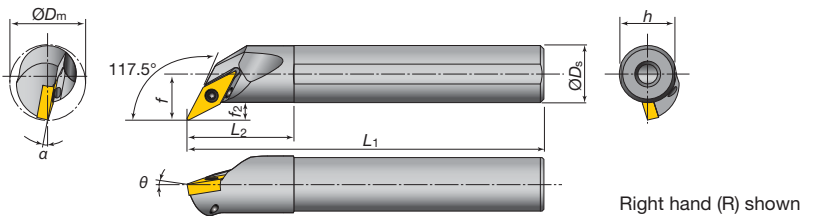
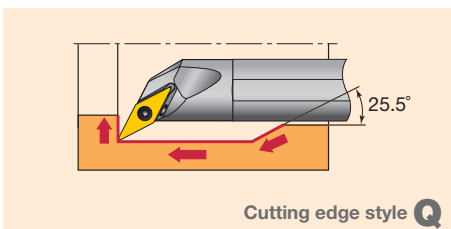

Steel shank

Toolholder Cat. No.	Stock		Min. bore dia. $\varnothing D_m$	Dimensions (mm)							Std. corner radius r_E	Applicable inserts	Parts		Torque (N·m)	
	R	L		$\varnothing D_s$	f	L_1	L_2	h	f_2	θ			α	Clamping screw		Wrench
A10K-SVQCR/L08-D135	●	●	13.5	10	8	125	20	9	3	-5°	-8°	0.4	VC□□0802	CSTB-2L	T-6F	0.6
New A16Q-SVQCR/L11-D215	●	●	21.5	16	13	180	30	15	4.9	-5°	-8°	0.4	VC□□1103	CSTB-2.5	T-8F	1.2
A25S-SVQCR/L16-D320			32	25	17	250	45	23	4.5	0°	-5°	0.8	VC□□1604	CSTB-3.5	T-15F	3.0
A32T-SVQCR/L16-D400			40	32	22	300	50	23	6	0°	-3°	0.8				
A40U-SVQCR/L16-D500			50	40	27	350	60	23	7	0°	-1°	0.8				

Carbide shank

Toolholder Cat. No.	Stock		Min. bore dia. $\varnothing D_m$	Dimensions (mm)							Std. corner radius r_E	Applicable inserts	Parts		Torque (N·m)	
	R	L		$\varnothing D_s$	f	L_1	L_2	h	f_2	θ			α	Clamping screw		Wrench
E10M-SVQCR/L08-D135	●	●	13.5	10	8	150	25	9	3	-5°	-8°	0.4	VC□□0802	CSTB-2L	T-6F	0.6
New E16R-SVQCR/L11-D215	●	●	21.5	16	13	200	32	15	4.9	-5°	-8°	0.4	VC□□1103	CSTB-2.5	T-8F	1.2

When using a right or left hand insert, the right hand insert (R) is used for the left hand toolholders (SVQCL □□ type), and the left hand insert (L) is used for the right hand toolholders (SVQCR □□ type).

● : Stocked items

SVUBR/L Boring & internal profiling S-type (Positive, screw-on)

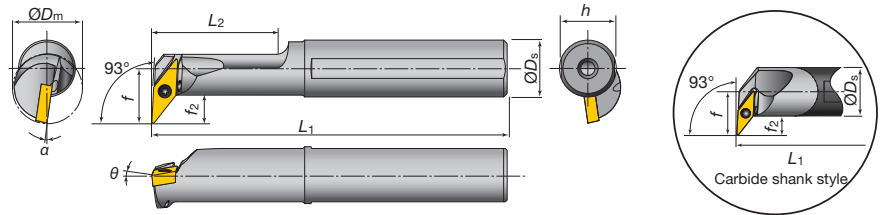
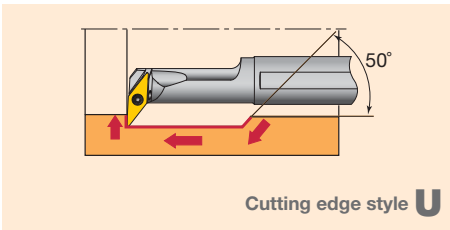

Steel shank

Toolholder Cat. No.	Stock		Min. bore dia. $\varnothing D_m$	Dimensions (mm)							Std. corner radius r_c	Applicable inserts	Parts		Torque (N·m)	
	R	L		$\varnothing D_s$	f	L_1	L_2	h	f_2	θ			α	Clamping screw		Wrench
A16Q-SVUBR/L11-D200	●	●	20	16	15.5	180	35	15	8	0°	-8°	0.4	VB□□1103	CSTB-2.5	T-8F	1.2
A20R-SVUBR/L11-D250	●	●	25	20	17.5	200	40	19	8	0°	-7°	0.4				
A25S-SVUBR/L16-D320	●	●	32	25	20.5	250	50	23	8.5	0°	-6°	0.8	VB□□1604	CSTB-3.5	T-15F	3.0

Carbide shank

Toolholder Cat. No.	Stock		Min. bore dia. $\varnothing D_m$	Dimensions (mm)							Std. corner radius r_c	Applicable inserts	Parts		Torque (N·m)	
	R	L		$\varnothing D_s$	f	L_1	L_2	h	f_2	θ			α	Clamping screw		Wrench
E16R-SVUBR/L11-D245	●	●	24.5	16	16	200	-	15	8	0°	-8°	0.4	VB□□1103	CSTB-2.5	T-8F	1.2
E20S-SVUBR/L11-D285	●	●	28.5	20	18	250	-	19	8	0°	-7°	0.4				
E25T-SVUBR/L16-D340	●	●	34	25	21	300	-	23	8.5	0°	-6°	0.8	VB□□1604	CSTB-3.5	T-15F	3.0

When using a right or left hand insert, the right hand insert (R) is used for the left hand toolholders (SVUBL □□ type), and the left hand insert (L) is used for the right hand toolholders (SVUBR □□ type).

SVUCR/L Boring & internal profiling S-type (Positive, screw-on)

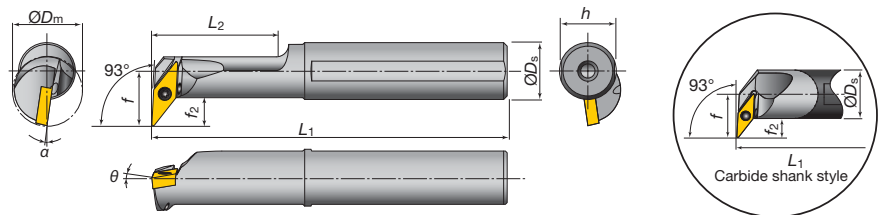
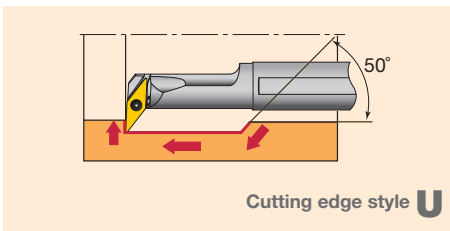

Steel shank

Toolholder Cat. No.	Stock		Min. bore dia. $\varnothing D_m$	Dimensions (mm)							Std. corner radius r_c	Applicable inserts	Parts		Torque (N·m)	
	R	L		$\varnothing D_s$	f	L_1	L_2	h	f_2	θ			α	Clamping screw		Wrench
A12M-SVUCR/L08-D160	●	●	16	12	11	150	30	11	5.5	0°	-8°	0.4	VC□□0802	CSTB-2L	T-6F	0.6
A25S-SVUCR/L16-D320	●	●	32	25	19	250	45	23	6.5	0°	-5°	0.8				
A32T-SVUCR/L16-D400			40	32	22	300	50	30	6	0°	-3°	0.8	VC□□1604	CSTB-3.5L	T-15F	3.0
A40U-SVUCR/L16-D500			50	40	27	350	60	37	7	0°	-1°	0.8				

Carbide shank

Toolholder Cat. No.	Stock		Min. bore dia. $\varnothing D_m$	Dimensions (mm)							Std. corner radius r_c	Applicable inserts	Parts		Torque (N·m)	
	R	L		$\varnothing D_s$	f	L_1	L_2	h	f_2	θ			α	Clamping screw		Wrench
E12Q-SVUCR/L08-D180	●	●	18	12	11.5	180	-	11	5.5	0°	-8°	0.4	VC□□0802	CSTB-2L	T-6F	0.6
E25T-SVUCR/L16-D320	●	●	32	25	19	300	-	23	6.5	0°	-5°	0.8	VC□□1604	CSTB-3.5	T-15F	3.0

When using a right or left hand insert, the right hand insert (R) is used for the left hand toolholders (SVUCL □□ type), and the left hand insert (L) is used for the right hand toolholders (SVUCR □□ type).

SVZBR/L Internal retracting S-type (Positive, screw-on)

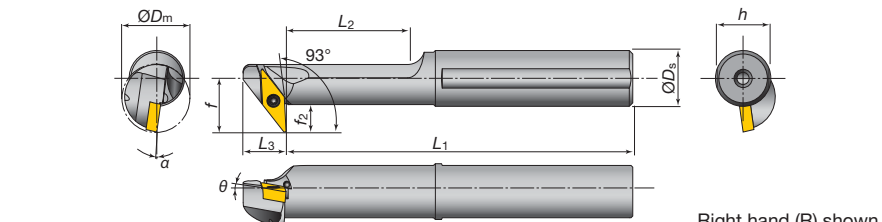
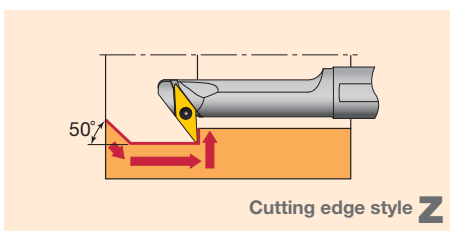

Steel shank

Toolholder Cat. No.	Stock		Min. bore dia. $\varnothing D_m$	Dimensions (mm)							Std. corner radius r_c	Applicable inserts	Parts		Torque (N·m)		
	R	L		$\varnothing D_s$	f	L_1	L_2	L_3	h	f_2			θ	α		Clamping screw	Wrench
A16Q-SVZBR/L11-D200	●	●	20	16	15.5	180	35	12.5	15	8	0°	-8°	0.4	VB□□1103	CSTB-2.5	T-8F	1.2
A20R-SVZBR/L11-D250	●	●	25	20	17.5	200	40	12.5	18	8	0°	-7°	0.4				
A25S-SVZBR/L16-D320	●	●	32	25	24	250	50	17.5	23	12	0°	-6°	0.8	VB□□1604	CSTB-3.5	T-15F	3.0
A32T-SVZBR/L16-D400	●	●	40	32	27.5	300	72	17.5	30	12	0°	-5°	0.8				

When using a right or left hand insert, the right hand insert (R) is used for the right hand toolholders (SVZBR □□ type), and the left hand insert (L) is used for the left hand toolholders (SVZBL □□ type).

● : Stocked items

SVZCR/L

Internal retracting

S-type (Positive, screw-on)

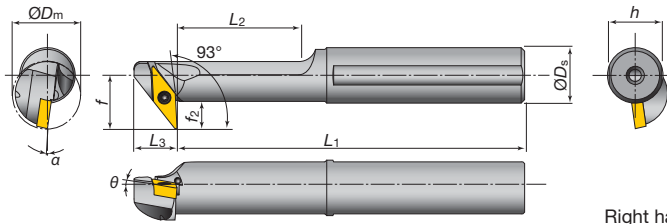
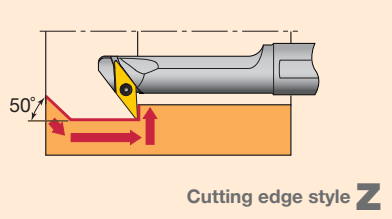

Right hand (R) shown

Steel shank

Toolholder Cat. No.	Stock		Min. bore dia. $\varnothing D_m$	Dimensions (mm)								Std. corner radius r_E	Applicable inserts	Parts		Torque (N·m)	
	R	L		$\varnothing D_s$	f	L_1	L_2	L_3	h	f_2	θ			α	Clamping screw		Wrench
A12M-SVZCR/L08-D160	●	●	16	12	11	150	30	10	11	5.5	0°	-8°	0.4	VC□□0802	CSTB-2L	T-6F	0.6

When using a right or left hand insert, the right hand insert (R) is used for the right hand toolholders (SVZCR □□ type), and the left hand insert (L) is used for the left hand toolholders (SVZCL □□ type).

SWUBR/L

Boring

S-type (Positive, screw-on)

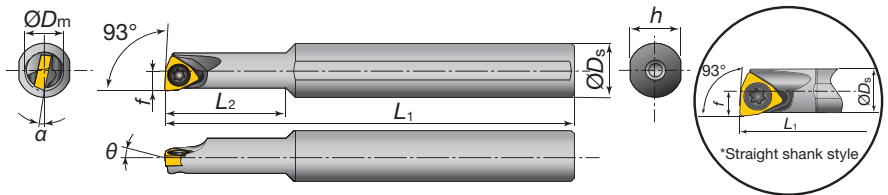
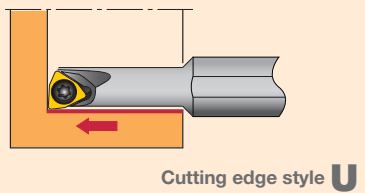

Right hand (R) shown

Steel shank

Toolholder Cat. No.	Stock		Min. bore dia. $\varnothing D_m$	Dimensions (mm)								Std. corner radius r_E	Applicable inserts	Parts		Torque (N·m)
	R	L		$\varnothing D_s$	f	L_1	L_2	h	f_2	θ	α			Clamping screw	Wrench	
New MINI *A05F-SWUBR/L03-D060	●	●	6	5	3	80	9	4.8	-	0°	-13°	0.4	WB□□0301	CSTB-2	T-6F	0.6
New MINI *A06G-SWUBR/L03-D070	●	●	7	6	3.5	90	11	5.75	-	0°	-12°					
New MINI *A07G-SWUBR/L03-D080	●	●	8	7	4	90	12	6.75	-	0°	-11°					
A08H-SWUBR03-D060	●		6	8	3.1	100	18	7.5	-	0°	-12°	0.4	WB□□0301	CSTB-2	T-6F	0.6
A08H-SWUBR03-D070	●		7	8	3.6	100	20	7.5	-	0°	-12°					

Carbide shank

Toolholder Cat. No.	Stock		Min. bore dia. $\varnothing D_m$	Dimensions (mm)								Std. corner radius r_E	Applicable inserts	Parts		Torque (N·m)
	R	L		$\varnothing D_s$	f	L_1	L_2	h	f_2	θ	α			Clamping screw	Wrench	
New MINI *E05G-SWUBR/L03-D060	●	●	6	5	3	90	10	4.8	-	0°	-13°	0.4	WB□□0301	CSTB-2	T-6F	0.6
New MINI *E06H-SWUBR/L03-D070	●	●	7	6	3.5	100	12	5.75	-	0°	-12°					
New MINI *E07H-SWUBR/L03-D080	●	●	8	7	4	100	14	6.75	-	0°	-11°					
E08K-SWUBR03-D060	●		6	8	3.1	125	30	7.5	-	0°	-12°	0.4	WB□□0301	CSTB-2	T-6F	0.6
E08K-SWUBR03-D070	●		7	8	3.6	125	40	7.5	-	0°	-11°					

When using a right or left hand insert, the right hand insert (R) is used for the left hand toolholders (SWUBL □□ type), and the left hand insert (L) is used for the right hand toolholders (SWUBR □□ type).

SEZPR/L

Internal retracting

S-type (Positive, screw-on)

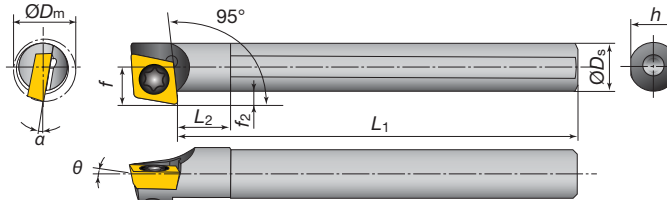
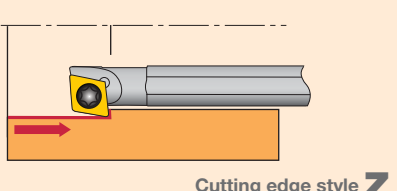

Right hand (R) shown

Steel shank

Toolholder Cat. No.	Stock		Min. bore dia. $\varnothing D_m$	Dimensions (mm)								Std. corner radius r_E	Applicable inserts	Parts		Torque (N·m)
	R	L		$\varnothing D_s$	f	L_1	L_2	h	f_2	θ	α			Clamping screw	Wrench	
New MINI *A04F-SEZPR/L03-D055	●	●	5.5	4	3.2	80	4	3.8	1.2	0°	-8°	0.2	EP□□03X1	CSTA-1.6	T-6F	0.6
New MINI *A05F-SEZPR/L03-D065	●	●	6.5	5	3.7	80	5	4.8	1.2	0°	-6°					

Carbide shank

Toolholder Cat. No.	Stock		Min. bore dia. $\varnothing D_m$	Dimensions (mm)								Std. corner radius r_E	Applicable inserts	Parts		Torque (N·m)
	R	L		$\varnothing D_s$	f	L_1	L_2	h	f_2	θ	α			Clamping screw	Wrench	
New MINI *E04G-SEZPR/L03-D055	●	●	5.5	4	3.2	90	5	3.8	1.2	0°	-8°	0.2	EP□□03X1	CSTA-1.6	T-6F	0.6
New MINI *E05G-SEZPR/L03-D065	●	●	6.5	5	3.7	90	6	4.8	1.2	0°	-6°					

When using a right or left hand insert, the right hand insert (R) is used for the right hand toolholders (SEZPR □□ type), and the left hand insert (L) is used for the left hand toolholders (SEZPL □□ type).

● : Stocked items

SVJBR/L

Internal sphere cutting

S-type (Positive, screw-on)

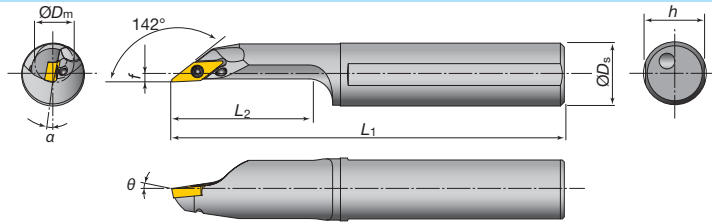
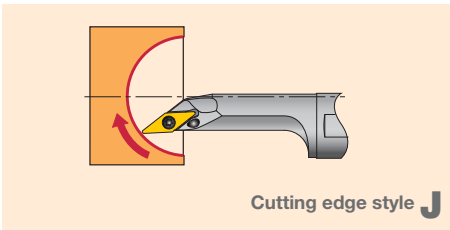

Right hand (R) shown

Steel shank

Toolholder Cat. No.	Stock		Min. bore dia. $\varnothing D_m$	Dimensions (mm)							Std. corner radius r_c	Applicable inserts	Parts		Torque (N·m)	
	R	L		$\varnothing D_s$	f	L_1	L_2	h	f_2	θ			a	Clamping screw		Wrench
A20R-SVJBR/L11-D250	●	●	25	20	2	200	40	18	-	-5°	-5°	0.4	VB□□1103	CSTB-2.5	T-8F	1.2
A25S-SVJBR/L11-D300	●	●	30	25	3.5	250	50	23	-	-5°	-5°	0.4				

When using a right or left hand insert, the right hand insert (R) is used for the left hand toolholders (SVJBL □□ type), and the left hand insert (L) is used for the right hand toolholders (SVJBR □□ type).

SVJCR/L

Internal sphere cutting

S-type (Positive, screw-on)

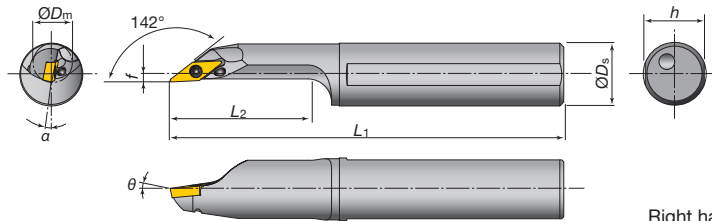
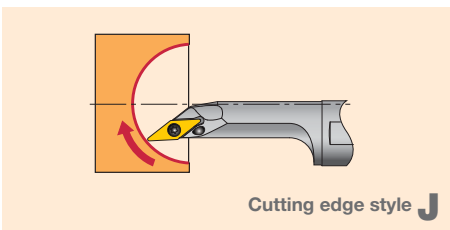

Right hand (R) shown

Steel shank

Toolholder Cat. No.	Stock		Min. bore dia. $\varnothing D_m$	Dimensions (mm)							Std. corner radius r_c	Applicable inserts	Parts		Torque (N·m)	
	R	L		$\varnothing D_s$	f	L_1	L_2	h	f_2	θ			a	Clamping screw		Wrench
A12M-SVJCR/L08-D160	●	●	16	12	2	150	28	11	-	-5°	-5°	0.4	VC□□0802	CSTB-2L	T-6F	0.6
A16Q-SVJCR/L08-D200	●	●	20	16	2	180	35	15	-	-5°	-5°	0.4				

When using a right or left hand insert, the right hand insert (R) is used for the left hand toolholders (SVJCL □□ type), and the left hand insert (L) is used for the right hand toolholders (SVJCR □□ type).

SEXPR/L

Boring & internal facing

S-type (Positive, screw-on)

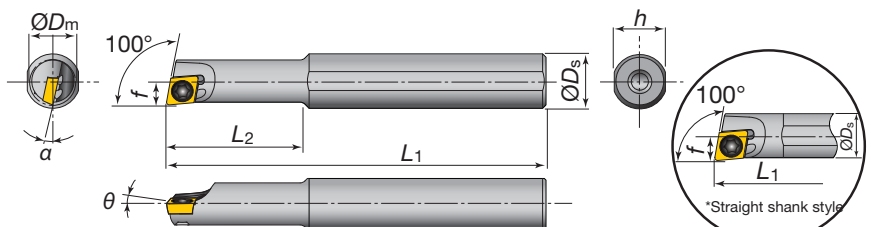
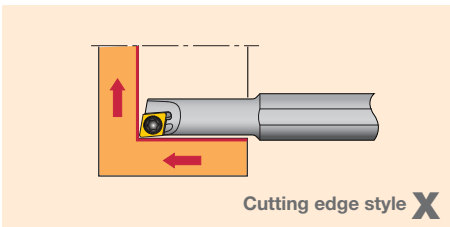

Right hand (R) shown

Steel shank

New MINI
New MINI
New MINI
New MINI

Toolholder Cat. No.	Stock		Min. bore dia. $\varnothing D_m$	Dimensions (mm)							Std. corner radius r_c	Applicable inserts	Parts		Torque (N·m)	
	R	L		$\varnothing D_s$	f	L_1	L_2	h	f_2	θ			a	Clamping screw		Wrench
*A04F-SEXPR/L03-D045	●	●	4.5	4	2.3	80	8	3.8	-	0°	-15°	0.2	EP□□03X1	CSTA-1.6	T-6F	0.6
*A04F-SEXPR/L03-D050	●	●	5	4	2.5	80	8	3.8	-	0°	-13°	0.2				
*A05F-SEXPR/L04-D055	●	●	5.5	5	2.75	80	9	4.8	-	0°	-12°	0.4	EP□□0401	CSTB-2	T-6F	0.6
*A06G-SEXPR/L04-D070	●	●	7	6	3.6	90	11	5.75	-	0°	-12°	0.4	EP□□0401	CSTB-2	T-6F	0.6
A08H-SEXPR/L04-D055	●	●	5.5	8	2.75	100	16	7.5	-	0°	-12°	0.4	EP□□0401	CSTB-2	T-6F	0.6
A08H-SEXPR/L04-D070	●	●	7	8	3.6	100	20	7.5	-	0°	-12°	0.4				0.6

Carbide shank

New MINI
New MINI
New MINI
New MINI

Toolholder Cat. No.	Stock		Min. bore dia. $\varnothing D_m$	Dimensions (mm)							Std. corner radius r_c	Applicable inserts	Parts		Torque (N·m)	
	R	L		$\varnothing D_s$	f	L_1	L_2	h	f_2	θ			a	Clamping screw		Wrench
*E04G-SEXPR/L03-D045	●	●	4.5	4	2.3	90	9	3.8	-	0°	-15°	0.2	EP□□03X1	CSTA-1.6	T-6F	0.6
*E04G-SEXPR/L03-D050	●	●	5	4	2.5	90	9	3.8	-	0°	-13°	0.2				
*E05G-SEXPR/L04-D055	●	●	5.5	5	2.75	90	10	4.8	-	0°	-12°	0.4	EP□□0401	CSTB-2	T-6F	0.6
*E06H-SEXPR/L04-D070	●	●	7	6	3.6	100	12	5.75	-	0°	-12°	0.4	EP□□0401	CSTB-2	T-6F	0.6
E08K-SEXPR/L04-D055	●	●	5.5	8	2.75	125	28	7.5	-	0°	-12°	0.4	EP□□0401	CSTB-2	T-6F	0.6
E08K-SEXPR/L04-D070	●	●	7	8	3.6	125	40	7.5	-	0°	-12°	0.4				0.6

When using a right or left hand insert, the right hand insert (R) is used for the left hand toolholders (SEXPL □□ type), and the left hand insert (L) is used for the right hand toolholders (SEXPR □□ type).

● : Stocked items

How to use SVJC(B)R/L-type tools

General machining information

The minimum machinable radius (R) of the internal sphere is 1/2 of the minimum bore diameter (ϕD_m).
The maximum machinable depth of the bore is within the L_2 size of the tool.

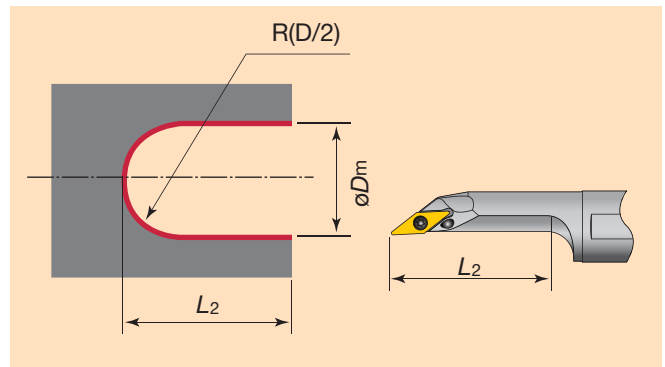

Cautionary points

To avoid insert breakage the tool point should not overrun the bore center.

To avoid burr, the depth of cut should be within the corner radius.

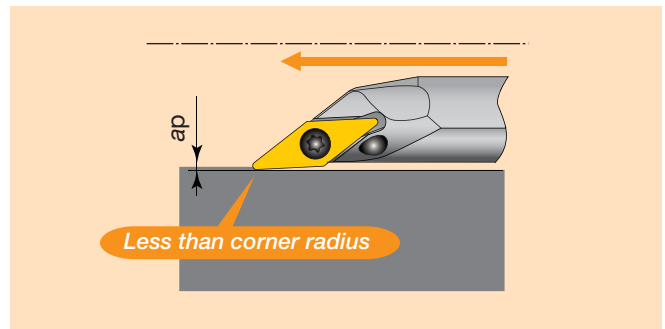
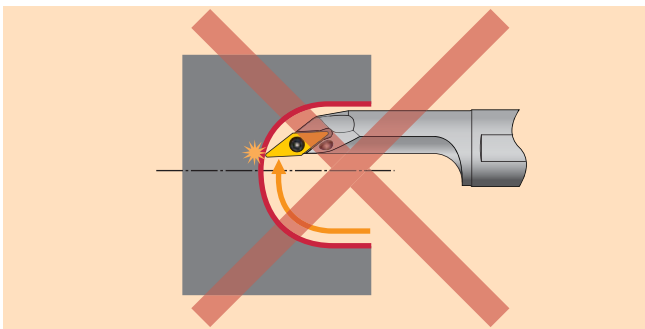

Machining examples

Machining of internal sphere

Work material : S45C
Toolholder : A12M-SVJCR08-D160
Insert : VCMT080204-PF (NS730)
Cutting speed : $V_c = \sim 100$ m/min
No of revs. : $n = 3000$ min⁻¹ (constant)
Feed : $f = 0.1$ mm/rev
Depth of cut : $a_p = 0.5$ mm

Work material : S45C
Toolholder : A12M-SVJCR08-D160
Insert : VCMT080204-PF (T9015)
Cutting speed : $V_c = \sim 100$ m/min
No of revs. : $n = 3000$ min⁻¹ (constant)
Feed : $f = 0.1$ mm/rev
 $f = 0.05$ mm/rev (only for plunging)
Depth of cut : $a_p = 0.5$ mm

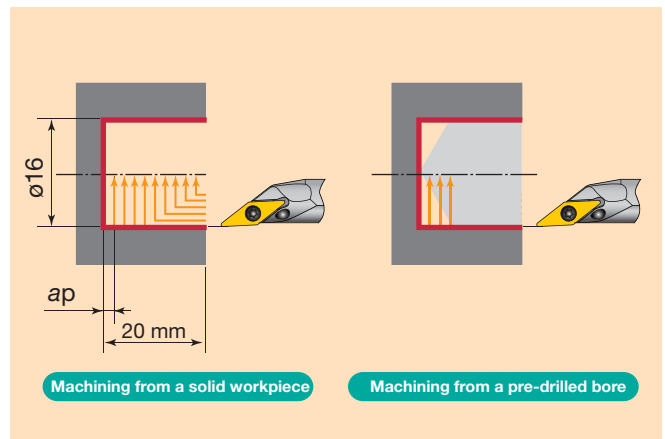
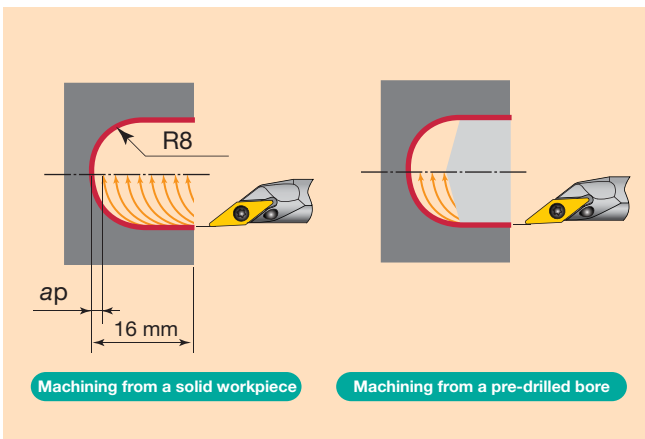

SYQBR/L Internal undercut & profiling S-type (Positive, screw-on)

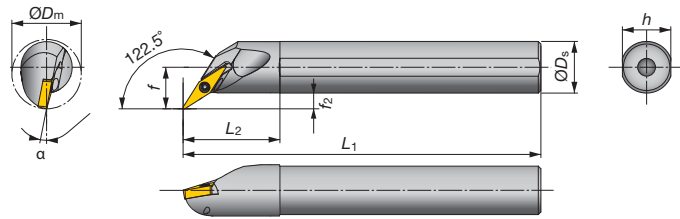
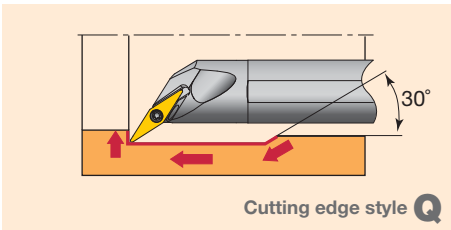

Steel shank

Right hand (R) shown

Toolholder Cat. No.	Stock		Min bore dia. $\varnothing D_m$	Dimensions (mm)							Std. corner radius r_ϵ	Applicable inserts	Parts		Torque (N·m)	
	R	L		$\varnothing D_s$	f	L_1	L_2	h	f_2	θ			α	Clamping screw		Wrench
A12M-SYQBR/L11-D170	●	●	17	12	10.5	150	24	11	4.5	-5°	-10°	0.4	YW□□11T2	CSTB-2L	T-6F	0.6
A16Q-SYQBR/L11-D215	●	●	21.5	16	13	180	30	15	5	-5°	-8°	0.4				

Carbide shank

Toolholder Cat. No.	Stock		Min bore dia. $\varnothing D_m$	Dimensions (mm)							Std. corner radius r_ϵ	Applicable inserts	Parts		Torque (N·m)	
	R	L		$\varnothing D_s$	f	L_1	L_2	h	f_2	θ			α	Clamping screw		Wrench
E12Q-SYQBR/L11-D170	●	●	17	12	10.5	180	27	11	4.5	-5°	-10°	0.4	YW□□11T2	CSTB-2L	T-6F	0.6
E16R-SYQBR/L11-D215	●	●	21.5	16	13	200	32	15	5	-5°	-8°	0.4				

SYUBR/L Boring & internal profiling S-type (Positive, screw-on)

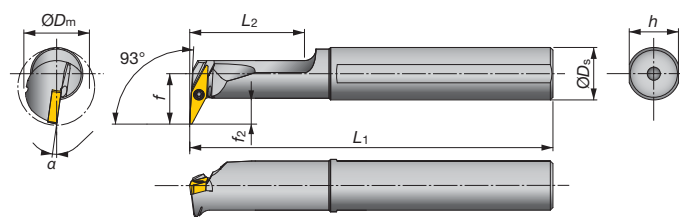
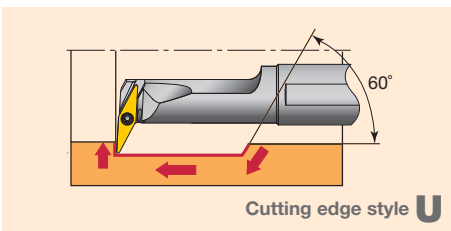

Steel shank

Right hand (R) shown

Toolholder Cat. No.	Stock		Min bore dia. $\varnothing D_m$	Dimensions (mm)							Std. corner radius r_ϵ	Applicable inserts	Parts		Torque (N·m)	
	R	L		$\varnothing D_s$	f	L_1	L_2	h	f_2	θ			α	Clamping screw		Wrench
A16Q-SYUBR/L11-D200	●	●	20	16	15.5	180	35	15	8	0°	-8°	0.4	YW□□11T2	CSTB-2L	T-6F	0.6

Carbide shank

Toolholder Cat. No.	Stock		Min bore dia. $\varnothing D_m$	Dimensions (mm)							Std. corner radius r_ϵ	Applicable inserts	Parts		Torque (N·m)	
	R	L		$\varnothing D_s$	f	L_1	L_2	h	f_2	θ			α	Clamping screw		Wrench
E12Q-SYUBR/L11-D200	●	●	20	12	13.5	180	27	11	7.5	0°	-8°	0.4	YW□□11T2	CSTB-2L	T-6F	0.6
E16R-SYUBR/L11-D245	●	●	24.5	16	16	200	32	15	8	0°	-8°	0.4				

● : Stocked items

Internal toolholders, negative type

PCLNR/L

Boring & internal facing

P-type (Negative, Lever-lock)

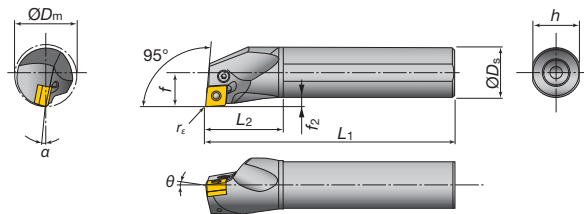
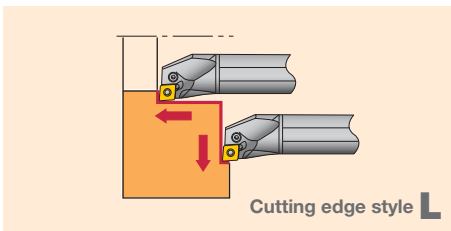

Right hand (R) shown

Steel shank

Toolholder Cat. No.	Stock		Min. bore.dia. $\varnothing D_m$	Dimensions (mm)							Std. corner radius r_e	Applicable inserts	Parts							Torque (N·m)	
	R	L		$\varnothing D_s$	f	L_1	L_2	h	f_2	θ			α	Shim	Lever	Clamping screw	Spring pin	Wrench	Oil supply attachment		Screw for oil hole
A16M-PCLNR/L09-D200	●	●	20	16	11	150	32	15	3	-6°	-14°	0.8	CN□□0903	-	LCL32N	LCS22A	-	P-2F	-	SSHMM3-4	1.7
A20Q-PCLNR/L09-D250	●	●	25	20	13	180	36	18	3	-6°	-12°	0.8		-	LCL32N	LCS22A	-	P-2F	EA-20	SSHMM5-6	
A25R-PCLNR/L09-D320	●	●	32	25	17	200	45	23	4.5	-6°	-11°	0.8	CN□□1204	-	LCL43N	LCS43	-	P-2.5	EA-25	SSHMM5-6	2.7
A25R-PCLNR/L12-D320	●	●	32	25	17	200	45	23	4.5	-6°	-13°	0.8		-	LCL43N	LCS43	-	P-2.5	EA-25	SSHMM5-6	
A32S-PCLNR/L12-D400	●	●	40	32	22	250	50	30	6	-6°	-11°	0.8	CN□□1204	LSC42BR/L	LCL4	LCS4	LSP4	P-3	EA-32	SSHMM6-6	4.8
A40T-PCLNR/L12-D500	●	●	50	40	27	300	60	37	7	-6°	-10°	0.8		-	LCL4	LCS4	LSP4	P-3	-	SSHMM6-6	
A50U-PCLNR/L12-D630	●	●	63	50	35	350	65	47	10	-6°	-8°	0.8	-	LCL4	LCS4	LSP4	P-3	-	SSHMM6-6	4.8	

When using a right or left hand insert, the right hand insert (R) is used for the left hand toolholders (PCLNL □□ type), and the left hand insert (L) is used for the right hand toolholders (PCLNR □□ type).

PDUNR/L

Internal profiling

P-type (Negative, Lever-lock)

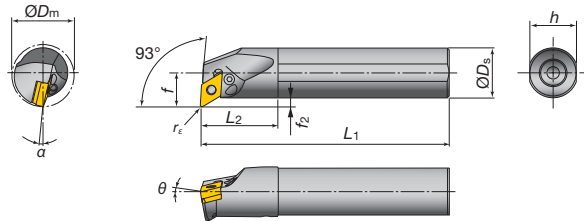
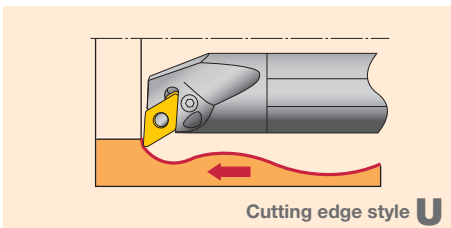

Right hand (R) shown

Steel shank

Toolholder Cat. No.	Stock		Min. bore.dia. $\varnothing D_m$	Dimensions (mm)							Std. corner radius r_e	Applicable inserts	Parts							Torque (N·m)	
	R	L		$\varnothing D_s$	f	L_1	L_2	h	f_2	θ			α	Shim	Lever	Clamping screw	Spring pin	Wrench	Oil supply attachment		Screw for oil hole
A20Q-PDUNR/L11-D250	●	●	25	20	13	180	36	18	3	-6°	-14°	0.8	DN□□1104	-	LCL33NL	LCS22A	-	P-2F	EA-20	SSHMM2.5-3	1.7
A25R-PDUNR/L11-D320	●	●	32	25	17	200	45	23	4.5	-6°	-12°	0.8		ELSD317BR/L	LCL33L	LCS3	LSP3	P-2.5	EA-25	SSHMM3-4	2.7
A32S-PDUNR/L15-D400	●	●	40	32	22	250	50	30	6	-6°	-13°	0.8	DN□□1504	LSD42BR/L	LCL4	LCS4	LSP4	P-3	EA-32	SSHMM5-6	4.8
A40T-PDUNR/L15-D500	●	●	50	40	27	300	60	37	7	-6°	-10°	0.8		-	LCL4	LCS4	LSP4	P-3	-	SSHMM6-6	
A50U-PDUNR/L15-D630	●	●	63	50	35	350	65	47	10	-6°	-8°	0.8	-	LCL4	LCS4	LSP4	P-3	-	SSHMM6-6	4.8	
A32S-PDUNR/L1506-D400	●	●	40	32	22	250	50	30	6	-6°	-13°	0.8	DN□□1506	ELSD42	LCL44	ELCS4	LSP4S	P-3	EA-32	SSHMM5-6	4.8
A40T-PDUNR/L1506-D500	●	●	50	40	27	300	60	37	7	-6°	-11°	0.8		-	LCL44	ELCS4	LSP4S	P-3	-	SSHMM6-6	
A50U-PDUNR/L1506-D630	●	●	63	50	35	350	65	47	10	-6°	-10°	0.8	-	LCL44	ELCS4	LSP4S	P-3	-	SSHMM6-6	4.8	

When using a right or left hand insert, the right hand insert (R) is used for the left hand toolholders (PDUNL □□ type), and the left hand insert (L) is used for the right hand toolholders (PDUNR □□ type).

PDZNR/L

Internal retracting

P-type (Negative, Lever-lock)

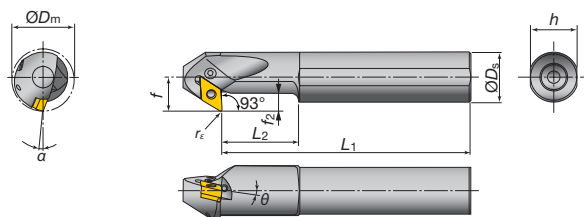
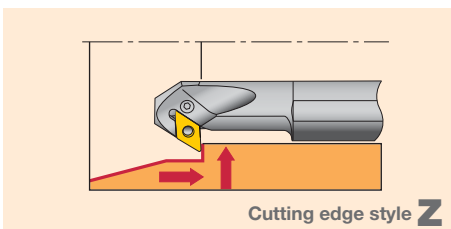

Right hand (R) shown

Steel shank

Toolholder Cat. No.	Stock		Min. bore.dia. $\varnothing D_m$	Dimensions (mm)							Std. corner radius r_e	Applicable inserts	Parts							Torque (N·m)	
	R	L		$\varnothing D_s$	f	L_1	L_2	h	f_2	θ			α	Shim	Lever	Clamping screw	Spring pin	Wrench	Oil supply attachment		Screw for oil hole
A32S-PDZNR/L15-D400	●	●	40	32	22	250	50	30	11.5	-6°	-13°	0.8	DN□□1504	LSZ42BR/L	LCL4	LCS4	LSP4	P-3	EA-32	SSHMM4-5	4.8
A40T-PDZNR/L15-D500	●	●	50	40	27	300	60	37	14.5	-6°	-10°	0.8		-	LCL4	LCS4	LSP4	P-3	-	SSHMM5-6	
A50U-PDZNR/L15-D630	●	●	63	50	35	350	65	47	14.5	-6°	-8°	0.8	-	LCL4	LCS4	LSP4	P-3	-	SSHMM6-6	4.8	

When using a right or left hand insert, the right hand insert (R) is used for the right hand toolholders (PDZNR □□ type), and the left hand insert (L) is used for the left hand toolholders (PDZNL □□ type).

● : Stocked items

PSKNR/L Through boring P-type (Negative, Lever-lock)

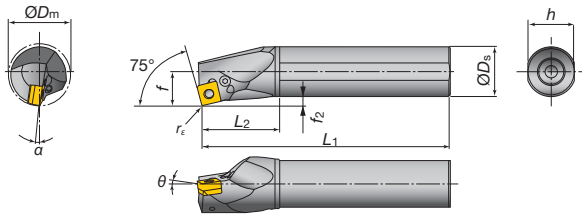
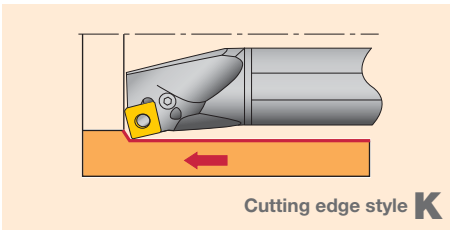

Right hand (R) shown

Steel shank

Toolholder Cat. No.	Stock		Min. bore dia. $\varnothing D_m$	Dimensions (mm)							Std. corner radius r_E	Applicable inserts	Parts							Torque (N·m)	
	R	L		$\varnothing D_s$	f	L_1	L_2	h	f_2	θ			α	Shim	Lever	Clamping screw	Spring pin	Wrench	Oil supply attachment		Screw for oil hole
A32S-PSKNR/L12-D400	●	●	40	32	22	250	50	30	6	-6°	-10°	0.8	SN□□1204	LSS42BR/L	LCL4	LCS4	LSP4	P-3	EA-32	SSHM4-5	4.8
A40T-PSKNR/L12-D500	●	●	50	40	27	300	60	37	7	-6°	-10°	0.8							-	SSHM6-6	
A50U-PSKNR/L12-D630	●	●	63	50	35	350	65	47	10	-6°	-8°	0.8							-	SSHM6-6	

When using a right or left hand insert, the right hand insert (R) is used for the left hand toolholders (PSKNL □□ type), and the left hand insert (L) is used for the right hand toolholders (PSKNR □□ type).

PTFNR/L Boring P-type (Negative, Lever-lock)

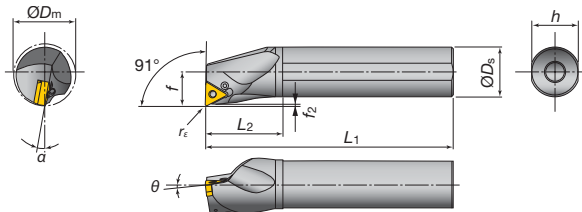
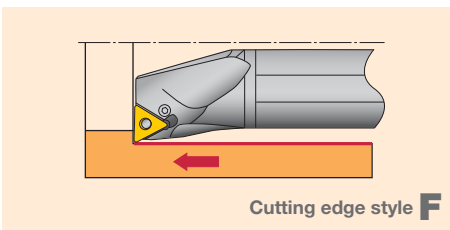

Right hand (R) shown

Steel shank

Toolholder Cat. No.	Stock		Min. bore dia. $\varnothing D_m$	Dimensions (mm)							Std. corner radius r_E	Applicable inserts	Parts							Torque (N·m)	
	R	L		$\varnothing D_s$	f	L_1	L_2	h	f_2	θ			α	Shim	Lever	Clamping screw	Spring pin	Wrench	Oil supply attachment		Screw for oil hole
A25R-PTFNR/L16-D320	●	●	32	25	17	200	45	23	1.2	-6°	-12°	0.8	TN□□1604	ELST317BR/L	LCL33	LCS3	LSP3	P-2.5	EA-25	SSHM4-5	2.7
A32S-PTFNR/L16-D400	●	●	40	32	22	250	50	30	1.1	-6°	-10°	0.8		LST317BR/L	LCL3				EA-32		
A40T-PTFNR/L16-D500	●	●	50	40	27	300	60	37	1.1	-6°	-10°	0.8		-	-				-	SSHM6-6	
A50U-PTFNR/L16-D630	●	●	63	50	35	350	65	47	1.1	-6°	-8°	0.8		-	-				-	SSHM6-6	

When using a right or left hand insert, the right hand insert (R) is used for the left hand toolholders (PTFNL □□ type), and the left hand insert (L) is used for the right hand toolholders (PTFNR □□ type).

PTUNR/L Boring P-type (Negative, Lever-lock)

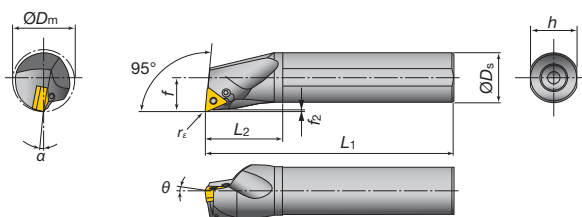
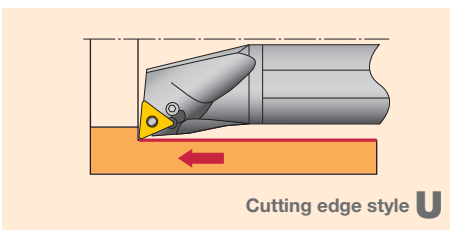

Right hand (R) shown

Steel shank

Toolholder Cat. No.	Stock		Min. bore dia. $\varnothing D_m$	Dimensions (mm)							Std. corner radius r_E	Applicable inserts	Parts							Torque (N·m)	
	R	L		$\varnothing D_s$	f	L_1	L_2	h	f_2	θ			α	Shim	Lever	Clamping screw	Spring pin	Wrench	Oil supply attachment		Screw for oil hole
A16M-PTUNR/L11-D200	●	●	20	16	11	150	32	15	1	-6°	-14°	0.4	TN□□1103	-	LCL22N	LCS22A	-	P-2F	-	SSHM3-4	1.7
A20Q-PTUNR/L11-D250	●	●	25	20	13	180	36	18	1	-6°	-12°	0.4		-	-	-	-	EA-20			
A25R-PTUNR/L16-D320	●	●	32	25	17	200	45	23	1.4	-6°	-12°	0.8	TN□□1604	ELST317BR/L	LCL33	LCS3	LSP3	P-2.5	EA-25	SSHM4-5	2.7
A32S-PTUNR/L16-D400	●	●	40	32	22	250	50	30	1.3	-6°	-10°	0.8		LST317BR/L	LCL3				EA-32		

* The insert hole conforms to the ISO standard.

* Tool holder length may be different to the ISO standard.

When using a right or left hand insert, the right hand insert (R) is used for the left hand toolholders (PTUNL □□ type), and the left hand insert (L) is used for the right hand toolholders (PTUNR □□ type).

● : Stocked items

PVUNR/L

Boring & internal profiling

P-type (Negative, Lever-lock)

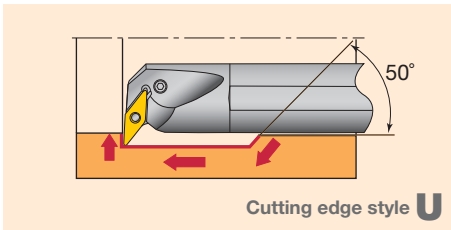

Cutting edge style **U**

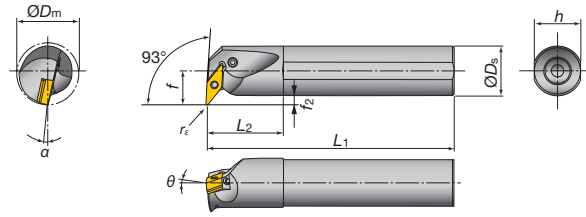

Right hand (R) shown

Steel shank

Toolholder Cat. No.	Stock		Min. bore dia. $\varnothing D_m$	Dimensions (mm)							Std. corner radius $r\epsilon$	Applicable inserts	Parts							Torque (N·m)	
	R	L		$\varnothing D_s$	f	L_1	L_2	h	f_2	θ			α	Shim	Lever	Clamping screw	Spring pin	Wrench	Oil supply attachment		Screw for oil hole
A25R-PVUNR/L16-D370	●	●	37	25	22	200	45	23	9.5	-5°	-14°	0.8	VN□□1604	LSV317BR/L	LCL3V	LCS3V	LSP3	P-2.5	EA-25	SSHM3-4	2.7
A32S-PVUNR/L16-D400	●	●	40	32	22	250	50	30	6	-5°	-12°	0.8							EA-32		
A40T-PVUNR/L16-D500	●	●	50	40	27	300	60	37	7	-5°	-10°	0.8							-	SSHM5-6	

PWLNR/L

Boring & facing

P-type (Negative, Lever-lock)

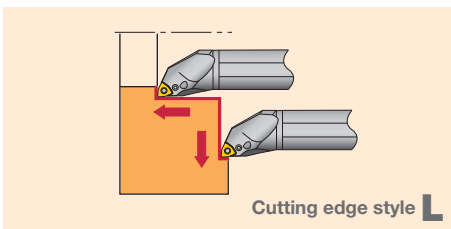

Cutting edge style **L**

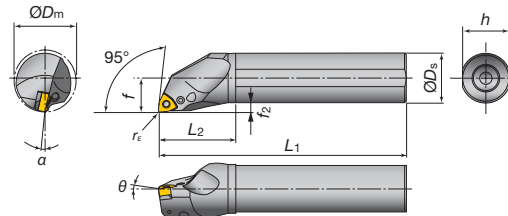

Right hand (R) shown

Steel shank

Toolholder Cat. No.	Stock		Min. bore dia. $\varnothing D_m$	Dimensions (mm)							Std. corner radius $r\epsilon$	Applicable inserts	Parts							Torque (N·m)	
	R	L		$\varnothing D_s$	f	L_1	L_2	h	f_2	θ			α	Shim	Lever	Clamping screw	Spring pin	Wrench	Oil supply attachment		Screw for oil hole
A16M-PWLNR/L06-D200	●	●	20	16	11	150	32	15	3	-8°	-17°	0.8	WN□□0604	-	LCL33N	LCS33	-	P-2F	-	SSHM3-4	1.7
A20Q-PWLNR/L06-D250	●	●	25	20	13	180	36	18	3	-6°	-14°	0.8		-	-	-	-	EA-20			
A25R-PWLNR/L06-D320	●	●	32	25	17	200	45	23	4.5	-6°	-12°	0.8		LSW312BR/L	LCL3	LCS3B	LSP3	P-2.5	EA-25	SSHM5-6	2.7
A32S-PWLNR/L06-D400	●	●	40	32	22	250	50	30	6	-6°	-11°	0.8	-	-	LCS3	-	P-2.5	EA-32	-	-	
A25R-PWLNR/L08-D320	●	●	32	25	17	200	45	23	4.5	-6°	-13°	0.8	WN□□0804	-	LCL43N	LCS43	-	P-2.5	EA-25	SSHM5-6	2.7
A32S-PWLNR/L08-D400	●	●	40	32	22	250	50	30	6	-6°	-11°	0.8		-	-	-	-	EA-32	-	-	
A40T-PWLNR/L08-D500	●	●	50	40	27	300	60	37	7	-6°	-10°	0.8		LSW42BR/L	LCL4	LCS4	LSP4	P-3	-	SSHM6-6	4.8

● : Stocked items

Inserts for small diameter applications

80° Rhombic, 7° positive with hole

Application	Chipbreaker	$f - a_p$	Insert Cat. No. (Metric)	Dimensions (mm)				Grades			
	Appearance (Cross section)			I.C. dia. ϕd	Thickness s	Hole dia. (ϕ) ϕd_1	Corner radius r_E	Coated SH730	Carbide TH10		
Finishing	W08 (G)		CCGT03X100R-W08	3.57	1.39	1.9	0.03	●	●		
	CCGT03X100L-W08		●					●			
	CCGT03X101R-W08		0.10				●	●			
	CCGT03X101L-W08						●	●			
	CCGT03X102R-W08		0.20				●	●			
	CCGT03X102L-W08						●	●			
	CCGT03X104R-W08		0.40				●	●			
	CCGT03X104L-W08						●	●			
	CCGT04T100R-W08		4.37				1.79	2.3	0.03	●	●
	CCGT04T100L-W08									●	●
	CCGT04T101R-W08								0.10	●	●
	CCGT04T101L-W08									●	●
	* CCGT04T102R-W08								0.20	●	●
	CCGT04T102L-W08									●	●
	CCGT04T104R-W08								0.40	●	●
	CCGT04T104L-W08									●	●
	JS (G)		CCGT03X101-JS	3.57	1.39	1.9	0.10	●			
	CCGT03X102-JS		●								
	CCGT03X104-JS		0.40				●				
	* CCGT04T101-JS						4.37	1.79	2.3	0.10	●
	CCGT04T102-JS		●								
	CCGT04T104-JS		0.20				●				
			0.40				●				

60° Triangular, 11° positive with hole

Application	Chipbreaker	$f - a_p$	Insert Cat. No. (Metric)	Dimensions (mm)				Grades	
	Appearance (Cross section)			I.C. dia. ϕd	Thickness s	Hole dia. (ϕ) ϕd_1	Corner radius r_E	Coated SH730	Carbide TH10
Finishing	W08 (G)		TPGT070100R-W08	4.37	1.59	2.58	0.03	●	●
	TPGT070100L-W08		●					●	
	TPGT070101R-W08		0.10				●	●	
	TPGT070101L-W08						●	●	
	TPGT070102R-W08		0.20				●	●	
	TPGT070102L-W08						●	●	
	TPGT070104R-W08		0.40				●	●	
	* TPGT070104L-W08						●	●	
	JS (G)		* TPGT070101-JS	4.37	1.59	2.58	0.10	●	
	TPGT070102-JS		●						
	TPGT070104-JS		0.40				●		
							●		

Note: Chipbreaker cross-sections are of * marked inserts.

● : Stocked items

80° Hexagon, 5° positive with hole

Application	Chipbreaker	$f - a_p$	Insert Cat. No. (Metric)	Dimensions (mm)				Grades				
	Appearance (Cross section)			I.C. dia. ϕd	Thickness s	Hole dia. (ϕ) ϕd_1	Corner radius r_ϵ	Coated		Cermet	Carbide	
								SH730	GH110	NS530	TH10	UX30
Finishing	W08 (G)		WBG030100R-W08	3.97	1.59	2.3	0.03	●		●	●	●
	WBG030100L-W08		0.10				●		●			
	WBG030101R-W08		0.20				●		●			
	WBG030101L-W08		0.40				●	●	●	●		
	* WBG030102R-W08											
	WBG030102L-W08											
	WBG030104R-W08											
	WBG030104L-W08											
	JS (G)		* WBG030101R-JS	3.97	1.59	2.3	0.10	●				
	WBG030101L-JS		0.20				●					
	WBG030102R-JS		0.40				●					
	WBG030102L-JS											
	WBG030104R-JS											
	WBG030104L-JS											

75° Rhombus, 11° positive with hole

Application	Chipbreaker	$f - a_p$	Insert Cat. No. (Metric)	Dimensions (mm)				Grades								
	Appearance (Cross section)			I.C. dia. ϕd	Thickness s	Hole dia. (ϕ) ϕd_1	Corner radius r_ϵ	Coated		Cermet		Carbide				
								SH730	J740	GH110	NS530	GT530	TH10	UX30		
Finishing	W08 (G)		EPGT03X100R-W08	3.57	1.39	1.9	0.03	●				●				
	EPGT03X100L-W08		0.10				●			●						
	EPGT03X101R-W08		0.20				●			●						
	EPGT03X101L-W08		0.40				●			●						
	* EPGT03X102R-W08															
	EPGT03X102L-W08															
	EPGT03X104R-W08															
	EPGT03X104L-W08															
	EPGT040100R-W08		3.97				1.59	2.3	0.03	●		●		●		
	EPGT040101R-W08								0.10	●			●			
	EPGT040102R-W08	0.20		●	●	●			●	●	●					
	EPGT040102L-W08	0.40		●	●	●			●	●	●					
	EPGT040104R-W08															
	EPGT040104L-W08															
	J08 (G)		EPGT040100L-J08	3.97	1.59	2.3	0.03	●	●							
	* EPGT040102L-J08		0.20				●	●								
	EPGT040104L-J08		0.40				●	●								
	JS (G)		EPGT03X101-JS	3.57	1.39	1.9	0.10	●								
EPGT03X102-JS			0.20				●									
EPGT03X104-JS			0.40				●									
* EPGT040101-JS			3.97	1.59	2.3	0.10	●									
EPGT040102-JS						0.20	●									
EPGT040104-JS						0.40	●									

Note: Chipbreaker cross-sections are of * marked inserts.

● : Stocked items

Standard cutting conditions

Work materials	Chip-breaker	Grades	Cutting Speed Vc (m/min)	Depth of cut ap (mm)	Feed f (mm/rev)			
					R0.03	R0.1	R0.2	R0.4
Steels S45C, SCM435 etc. (C45, 35CrMo4 etc.)	W08 J08	SH730	50 - 100 - 150	0.05 - 0.5 - 1.0	0.005 ~ 0.01 ~ 0.02	0.01 ~ 0.03 ~ 0.05	0.02 ~ 0.06 ~ 0.10	0.05 ~ 0.10 ~ 0.15
Stainless steels SUS303, SUS304 etc. (X10CrNiS18-9 etc.)			30 - 100 - 150					
Grey cast irons Ductile cast irons FC250, FCD450 etc. (GG25, GGG45 etc.)		TH10	30 - 70 - 100					
Aluminium alloys Copper alloys Si < 13%			100 - 300 - 500					
Titanium Titanium alloys Ti-6Al-4V etc.		SH730	30 - 60 - 100					

Sleeves

BLM type (Round shank for Stream Jet Bar MINI)

New

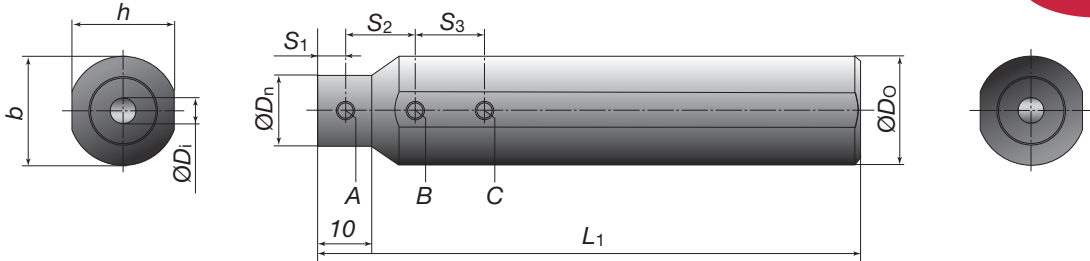

*Optional

Cat. No.	Stock	Dimensions (mm)									Replacement parts						
		øDo	øDi	øDn	L1	h	b	S1	S2	S3	Clamping screws			Wrench	Seal cap* (Inner screw)		
											A	B	C				
BLM159-04	●	15.875	4	15	100	15	15.875	5	15	15	SSH4-4	SSH4-4	SSH4-4	P-2	CA-16 (M6)		
BLM159-05	●		5						20	20							
BLM159-06	●		6						20	20							
BLM159-07	●		7						20	20							
BLM16-04	●	16	4	15	100	15	16	5	15	15	SSH4-4	SSH4-4	SSH4-4	P-2	CA-16 (M6)		
BLM16-05	●		5						20	20							
BLM16-06	●		6						20	20							
BLM16-07	●		7						20	20							
BLM19-04	●	19.05	4	18	100	18	19.05	5	15	15	SSH4-4	SSH4-6	SSH4-6	P-2	CA-16 (M6)		
BLM19-05	●		5						SSH4-4	SSH4-4		SSH4-4					
BLM19-06	●		6						SSH4-4	SSH4-4		SSH4-4					
BLM19-07	●		7						SSH4-4	SSH4-4		SSH4-4					
BLM20-04	●	20	4	13	100	19	20	5	15	15	SSH4-4	SSH4-6	SSH4-6	P-2	CA-16 (M6)		
BLM20-05	●		5						14	SSH4-4		SSH4-6	SSH4-6				
BLM20-06	●		6						15	SSH4-4		SSH4-4	SSH4-4				
BLM20-07	●		7						16	SSH4-4		SSH4-4	SSH4-4				
BLM22-04	●	22	4	13	125	21	22	5	15	15	SSH4-4	SSH4-6	SSH4-6	P-2	CA-16 (M6)		
BLM22-05	●		5						14	SSH4-4						SSH4-6	SSH4-6
BLM22-06	●		6						15	SSH4-4						SSH4-6	SSH4-6
BLM22-07	●		7						16	SSH4-4						SSH4-6	SSH4-6
BLM25-04	●	25	4	13	125	24	25	5	15	15	SSH4-4	SSH4-8	SSH4-8	P-2	CA-16 (M6)		
BLM25-05	●		5						14	SSH4-4		SSH4-8	SSH4-8				
BLM25-06	●		6						15	SSH4-4		SSH4-6	SSH4-6				
BLM25-07	●		7						16	SSH4-4		SSH4-6	SSH4-6				
BLM254-04	●	25.4	4	13	125	24	25.4	5	15	15	SSH4-4	SSH4-8	SSH4-8	P-2	CA-16 (M6)		
BLM254-05	●		5						14	SSH4-4		SSH4-8	SSH4-8				
BLM254-06	●		6						15	SSH4-4		SSH4-6	SSH4-6				
BLM254-07	●		7						16	SSH4-4		SSH4-6	SSH4-6				

● : Stocked items

BLS type (Square shank)

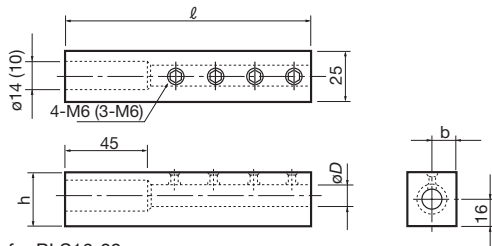

() is for BLS16-08

Cat. No.	Stock	Applicable shank dia. øD	Dimensions (mm)		
			ℓ	h	b
BLS16-08	●	8	125	28	12.5
BLS16-10	●	10			
BLS16-12	●	12			

BLS-C type (Square shank)

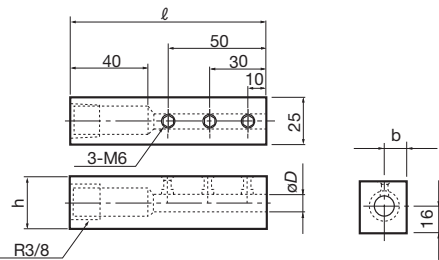

Cat. No.	Stock	Applicable shank dia. øD	Dimensions (mm)		
			ℓ	h	b
BLS16-08C	●	8	100	28	12.5
BLS16-10C	●	10			
BLS16-12C	●	12			

BLM type (Round shank)

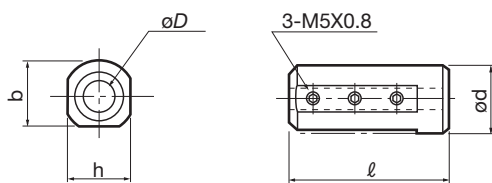

Above drawing shows BLM25-**C type.

Cat. No.	Stock	Applicable shank dia. øD	Dimensions (mm)			
			ød	ℓ	h	b
BLM19-08	●	8	19.05	100	18	18
BLM20-08	●		20		19	
BLM22-08	●		22	125	21	21
BLM254-08	●		25.4		24	
BLM25-08C	●		10	25	55	24
BLM25-10C	●					
BLM25-12C	●					

BLC type (Standard type)

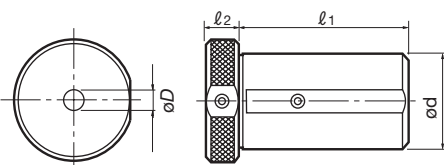

Cat. No.	Stock	Applicable shank dia. øD	Dimensions (mm)		
			ℓ1	ℓ2	ød
BLC40-8	●	8	73	13	40
BLC40-10	●	10			
BLC40-12	●	12			
BLC40-16	●	16			

BLC type (Short type)

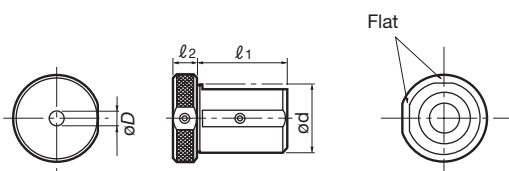

Cat. No.	Stock	Applicable shank dia. øD	Dimensions (mm)		
			ℓ1	ℓ2	ød
BLC32-8C	●	8	45	20	32
BLC32-10C	●	10			
BLC32-12C	●	12			
BLC40-8C	●	8	55	13	40
BLC40-10C	●	10			
BLC40-12C	●	12			
BLC40-16C	●	16			

● : Stocked items

Practical examples

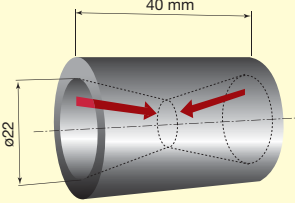
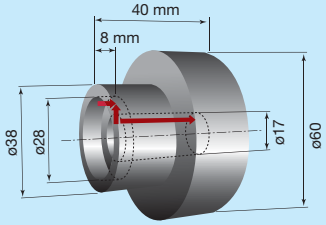
Work piece type		Machine parts	Automotive parts
Toolholder		A16Q-STUPR1103-D180	A12M-SDUCR07-D160
Insert		TPMT110308-PS	DCMT070204-PS
Grade		T6030	GT730
Work material		SUS304 (X5CrNi18-9)	S45C (C45)
			
Cutting conditions	Cutting speed: V_c (m/min)	120	170
	Feed : f (mm/rev)	0.15	0.15
	Depth of cut: ap (mm)	0.1 - 3.0	0.25
	Coolant	Water soluble (External supply)	Water soluble (Internal supply)
Results		<p>Increased tool life and machining stability</p> <p>Number of work-pieces machined:</p> <p>STREAMJET BAR 150 pcs.</p> <p>Competitor 50 ~ 100 pcs.</p> <p>When competitor's tools are used, inserts often fractured due to chip re-cutting and tool life is unstable. With excellent chip control, the Stream Jet Bar excels in chip control and eliminates unexpected insert breakage caused by chip re-cutting and delivers consistent tool life. The tool also disposes of chip tangling and gives outstanding chip evacuation when taper boring.</p>	<p>50 % increased tool life</p> <p>Number of work-pieces machined:</p> <p>STREAMJET BAR 300 pcs.</p> <p>Competitor 200 pcs.</p> <p>Compared with the previously used competitor's tool, the tool life was increased by 50 % and the surface finish was also improved. Even when machining the small diameter ($\phi 17$) portion, chip control was improved.</p>

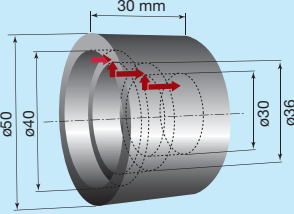
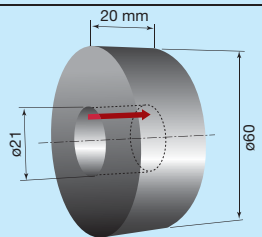
Work piece type		Automotive parts	Automotive parts
Toolholder		A16Q-SDUCR07-D200	A16Q-SCLPR09-D180
Insert		DCMT070208-PS	CPMT090308-PS
Grade		GH730	NS730
Work material		SCr420H (20Cr4H)	SCM42HV
			
Cutting conditions	Cutting speed: V_c (m/min)	70	185
	Feed : f (mm/rev)	0.18	0.15
	Depth of cut: ap (mm)	0.2	0.4
	Coolant	Water soluble (Internal supply)	Water soluble (Internal supply)
Results		<p>Increased tool life and machining stability</p> <p>Number of work-pieces machined:</p> <p>STREAMJET BAR 40 pcs. Fixed number</p> <p>Competitor $\times 20 \sim 40$ pcs. Fractured</p> <p>Competitor tools often showed unexpected fracture of the cutting edge and tool life was inconsistent. The Stream Jet Bar could suppress unexpected fracture and provide consistently long tool life.</p>	<p>20 % increased productivity</p> <p>Productivity</p> <p>STREAMJET BAR 600 pcs./H</p> <p>Competitor 500 pcs./H</p> <p>Competitor's tooling often showed chips tangling around the toolholder resulting in the machine having to be stopped to remove chips. This drastically reduces productivity. The Stream Jet Bar suppressed chip tangling and prevented unnecessary machine stoppages. The productivity per hour was improved by 20 % from 500 pcs./H to 600 pcs./H.</p>

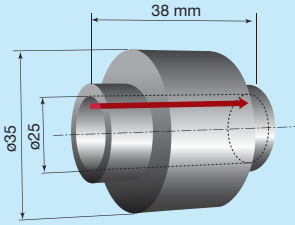
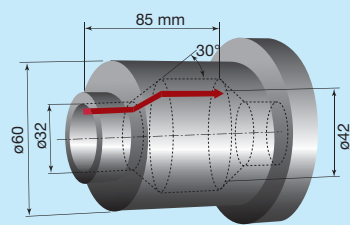
Work piece type		Automotive parts	Machine parts
Toolholder		A12M-STUPR1103-D140	E20S-SDUCR11-D270
Insert		TPMT110304-PM	DCMT11T304-PS
Grade		GH730	T9115
Work material		S20C (C22)	S35C (C35)
			
Cutting conditions	Cutting speed: V_c (m/min)	220	70 - 160
	Feed : f (mm/rev)	0.2	0.12 - 0.2
	Depth of cut: a_p (mm)	0.5	1.0
	Coolant	Water soluble (External supply)	Water soluble (Internal supply)
Results		<p>Increased cutting speeds (Productivity increased 20 %)</p> <p>Number of work-pieces machined / H</p> <p>STREAMJETBAR $V_c = 220$ m/min</p> <p>Competitor $V_c = 180$ m/min</p> <p>Previously the cutting speed was limited to 180 m/min to suppress chatter. When using the Stream Jet Bar, chatter did not occur at speeds up to 220 m/min and the surface finish after machining the same number of parts was superior to those obtained with previous tools. The dimensional accuracy of the machined bore was also improved.</p>	<p>67 % increased tool life</p> <p>Number of work-pieces machined:</p> <p>STREAMJETBAR 100 pcs.</p> <p>Competitor 60 pcs.</p> <p>Compared with a competitor chipbreaker tool for medium cutting, the PS-type chipbreaker improved chip control. Under stable machining, the Stream Jet Bar improved chip evacuation and eliminated insert fracturing caused by chip re-cutting. The result is improved tool life and surface finish.</p>

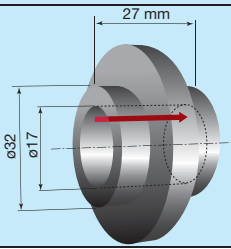
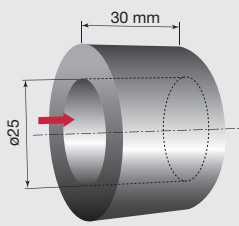
Work piece type		Automotive parts	Automotive parts
Toolholder		E12Q-SCLCR06-D140	E20S-SDQCR11-D250
Insert		CCMT060208-PM	2QP-DCGW11T304
Grade		T9125	BXM10
Work material		S45C (C45)	S45C (C45 Hardened steels)
			
Cutting conditions	Cutting speed: V_c (m/min)	200	200
	Feed : f (mm/rev)	0.3	0.06
	Depth of cut: a_p (mm)	1.0	0.08
	Coolant	Water soluble (External supply)	Dry
Results		<p>Twice the productivity</p> <p>Number of work-pieces machined:</p> <p>STREAMJETBAR One pass</p> <p>Competitor Two pass</p> <p>When using a competitor's tool, roughing and medium finishing processes were needed to machine this component. The high level of rigidity with the Stream Jet Bar allowed one-pass machining. Chip control and surface finish were also improved.</p>	<p>By switching from internal grinding, the productivity was increased due to the shortened machining process. In addition, the machining costs could be reduced by eliminating the grinding-sludge disposal cost.</p>



Tungaloy Corporation (Head office)

11-1 Yoshima-Kogyodanchi
Iwaki-city, Fukushima, 970-1144 Japan
Phone: +81-246-36-8501 Fax: +81-246-36-8542
<http://www.tungaloy.co.jp/>

Tungaloy America, Inc.

3726 N Ventura Drive, Arlington Heights, IL 60004, U.S.A.
Phone: +1-888-554-8394 Fax: +1-888-554-8392
<http://www.tungaloyamerica.com>

Tungaloy Canada

432 Elgin St. Unit 3, Brantford, Ontario N3S 7P7, Canada
Phone: +1-519-758-5779 Fax: +1-519-758-5791
<http://www.tungaloyamerica.com/>

Tungaloy de Mexico S.A.

C Los Arellano 113, Parque Industrial Siglo XXI
Aguascalientes, AGS, Mexico 20290
Phone: +52-449-929-5410 Fax: +52-449-929-5411
<http://www.tungaloyamerica.com/>

Tungaloy do Brasil Comércio de Ferramentas de Corte Ltda.

Rua dos Sabias N.104
13280-000 Vinhedo, São Paulo, Brazil
Phone: +55-19-38262757 Fax: +55-19-38262757
<http://www.tungaloy.co.jp/br/>

Tungaloy Germany GmbH

Elisabeth-Selbert-Str. 3
D-40764 Langenfeld, Germany
Phone: +49-2173-90420-0 Fax: +49-2173-90420-19
<http://www.tungaloy.de>.

Tungaloy France S.A.S.

ZA Courtaboeuf - Le Rio, 1 rue de la Terre de feu
F-91952 Courtaboeuf Cedex, France
Phone: +33-1-6486-4300 Fax: +33-1-6907-7817
<http://www.tungaloy-eu.com>

Tungaloy Italia S.r.l.

Via E. Andolfato 10
I-20126 Milano, Italy
Phone: +39-02-252012-1 Fax: +39-02-252012-65
<http://www.tungaloy-eu.com/>

Tungaloy Czech s.r.o

Tuřanka 115
CZ-627 00 Brno, Czech Republic
Phone: +420-532 123 391 Fax: +420-532 123 392
<http://www.tungaloy.co.jp/cz/>

Tungaloy Ibérica S.L.

C/La Pau, nº46
E-08243 Manresa (BCN), SPAIN
Phone: +34 93 1131360 Fax: +34 93 1131361
<http://www.tungaloy.co.jp/es/>

Tungaloy Scandinavia AB

S:t Lars Väg 42A
SE-22270 Lund, Sweden
Phone: +46-462119200 Fax: +46-462119207
<http://www.tungaloy.co.jp/se/>

Tungaloy Rus, LLC

36-G Kostukova str.
308012 Belgorod, Russia
Phone: +7 4722 58 57 57 Fax: +7 4722 58 57 83
<http://www.tungaloy.co.jp/ru/>

Tungaloy Polska Sp. z o.o.

ul. Genewska 24
03-963 Warszawa, Poland
Phone: +48-22-617-0890 Fax: +48-22-617-0890
<http://www.tungaloy.co.jp/pl/>

Tungaloy U.K. Ltd

Woodgate Business Park, Bartley Green
Birmingham B32 3DE, UK
Phone: +44 121 244 3064 Fax: +44 121 270 9694
<http://www.tungaloy.co.jp/uk> salesinfo@tungaloyuk.co.uk

Tungaloy Cutting Tool (Shanghai) Co.,Ltd.

Rm No 401 No.88 Zhabei, Jiangchang No.3 Rd
Shanghai 200436, China
Phone: +86-21-3632-1880 Fax: +86-21-3621-1918
<http://www.tungaloy.co.jp/tcts/>

Tungaloy Cutting Tool (Thailand) Co.,Ltd.

11th Floor, Sorachai Bldg. 23/7, Soi Sukhumvit 63
Klongtonnue, Wattana, Bangkok 10110, Thailand
Phone: +66-2-714-3130 Fax: +66-2-714-3134
<http://www.tungaloy.co.th/>

Tungaloy Singapore (Pte.), Ltd.

50 Kallang Avenue #06-03 Noel Corporate Building
Singapore 339505
Phone: +65-6391-1833 Fax: +65-6299-4557
<http://www.tungaloy.co.jp/tspl/>

Tungaloy India Pvt. Ltd.

Unit#13, B wing, 8th Floor, Kamala Mills Compound
Trade World, Lower Parel (West), Mumbai - 4000 13. India
Phone: +91-22-6124-8804 Fax: +91-22-6124-8899
<http://www.tungaloy.co.jp/in/>

Tungaloy Korea Co., Ltd

#1312, Byucksan Digital Valley 5-cha
60-73 Gasan-dong, Geumcheon-gu
153-788 Seoul, Korea
Phone: +82-2-6393-8930 Fax: +82-2-6393-8952
<http://www.tungaloy.co.jp/kr/>

Tungaloy Malaysia Sdn Bhd

50 K-2, Kelana Mall, Jalan SS6/14, Kelana Jaya, 47301
Petaling Jaya, Selangor Darul Ehsan, Malaysia
Phone: +603-7805-3222 Fax: +603-7804-8563
<http://www.tungaloy.co.jp/my/>

Tungaloy Australia Pty Ltd

Unit 308/33 Lexington Drive
Bella Vista NSW 2153, Australia
Phone: +612-9672-6844 Fax: +612-9672-6866
<http://www.tungaloy.co.jp/au>

Distributed by:



ISO 9001 certified
QC00J0056
Tungaloy Corporation

18/10/1996

ISO 14001 certified
EC97J1123
Tungaloy Group
Japan site and Asian
production site
26/11/1997